



# GUIDEBOOK FOR RESCUERS

## RESCUING AND SALVAGING ŠKODA BRAND VEHICLES AFTER AN ACCIDENT



**Note:**

These guidelines have been created exclusively for rescue teams, who have special training in the field of technical assistance for road accidents and therefore the activities described in this guide.

Specifications and optional equipment in ŠKODA brand vehicles, as well as the vehicles offered by ŠKODA AUTO a.s., are constantly changing. Therefore ŠKODA AUTO as expressly reserves the right to make changes to this documentation at any time.

Please note that the information contained in this documentation is not intended for end users and also not for workshops and dealers. End users will find detailed information on the features of their vehicle, including important safety information for vehicle and occupant safety, in the owner's manual of each ŠKODA brand vehicle.

Workshops and dealers can obtain the necessary information about the repair from known sources.

Issue 12/2019



**The rescue guide was drawn up in collaboration with the fire rescue corps of ŠKODA AUTO as and the fire rescue corps of the Česká republika district.**

Order number: S00 5186 60 20



## Contents

<b>Guidelines for Rescue Services</b>	<b>Page 7</b>
Search and rescue from crashed ŠKODA vehicles	Page 7
<b>Battery and its disconnection, battery disconnection element</b>	<b>Page 8</b>
Battery	Page 8
Pyrotechnic element for separating the starter cable from the battery for Superb II vehicles with the 3.6 l/191 kW FSI engine	Page 8
Notes on disconnecting the vehicle battery	Page 9
<b>Airbag</b>	<b>Page 13</b>
Overall view of the airbag system	Page 14
Airbag control system	Page 14
Airbag deployment	Page 15
Schematic figure for belt tensioner and front airbag inflation timing in a frontal accident	Page 16
<b>Front airbags</b>	<b>Page 17</b>
Driver airbag	Page 17
Passenger airbag	Page 18
Knee airbag	Page 19
Head airbag	Page 19
Side airbags	Page 19
Head/thorax airbag	Page 20
<b>Airbag inflators</b>	<b>Page 21</b>
Solid propellant inflators	Page 21
Hybrid inflators	Page 22
Inflators	Page 23
Gas springs	Page 23
Identification of the airbag in the vehicle	Page 24
<b>Belt tensioners</b>	<b>Page 26</b>
<b>Belt force limiters</b>	<b>Page 28</b>
<b>Belt tensioner variants</b>	<b>Page 29</b>
Cylindrical belt tensioners	Page 29
Rack belt tensioners	Page 30
Ball belt tensioners	Page 31
Wankel belt tensioner	Page 32
Reversible belt tensioners	Page 33
<b>Active pedestrian protection</b>	<b>Page 34</b>
<b>Body of ŠKODA vehicles</b>	<b>Page 36</b>
Side impact protection	Page 36
Body separation areas	Page 37
Armoured vehicles	Page 37
Seven-seater vehicles	Page 38
<b>Body structure of ŠKODA vehicles</b>	<b>Page 39</b>
Body structure: Felicia	Page 39
Body structure: Fabia I	Page 40
Body structure: Octavia I	Page 41
Body structure: Superb I	Page 42

Body structure: Octavia II	Page 43
Body structure: Fabia II	Page 44
Body structure: Roomster	Page 45
Body structure: Superb II	Page 46
Body structure: Yeti	Page 47
Body structure: Citigo	Page 48
Body structure: Rapid	Page 49
Body structure: Octavia III	Page 50
Body structure of Fabia III	Page 51
Body structure of Superb III	Page 52
Body structure of Kodiaq	Page 53
Body structure of Karoq	Page 54
Body structure of Scala	Page 55
Body structure of Kamiq	Page 56
Body structure of Octavia IV	Page 57
Body structure of Citigo-e IV	Page 58
<b>Vehicle glazing</b>	<b>Page 59</b>
Tempered safety glass (TSG)	Page 59
Laminated safety glass (LSG)	Page 59
<b>Alternative fuel vehicles</b>	<b>Page 60</b>
Natural gas vehicles	Page 60
ŠKODA natural-gas-powered Citigo vehicle	Page 60
Natural gas powered vehicle ŠKODA Octavia III	Page 61
ŠKODA Octavia III Facelift natural gas vehicle (from 01/2019 onwards)	Page 62
ŠKODA SCALA and KAMIQ natural gas vehicles	Page 63
Physical properties of natural gas	Page 64
<b>Safety devices</b>	<b>Page 65</b>
Natural gas tank multifunction valve	Page 65
Electromagnetic valve for tank shut-off	Page 66
Flow limiter	Page 67
Thermal fuse	Page 68
Mechanical shut-off valve	Page 68
<b>Vehicle identification</b>	<b>Page 69</b>
Sticker on the rear window	Page 69
Citigo vehicle marking on the tailgate	Page 69
Octavia III vehicle marking on the tailgate	Page 70
<b>Usage instructions for a natural gas vehicle</b>	<b>Page 71</b>
Vehicle fire	Page 71
Traffic accident/gas outlet on a natural gas vehicle	Page 72
ŠKODA Citigo vehicle natural gas tanks	Page 72
Natural gas tank of the ŠKODA Octavia III vehicle	Page 73
Manually close valves on the gas tanks	Page 74
<b>LPG vehicles</b>	<b>Page 79</b>
Physical properties of LPG (liquefied petroleum gas)	Page 80
<b>Safety devices</b>	<b>Page 81</b>

Multifunction valve for LPG tank	Page 81
Valve for tank shut-off	Page 81
Safety pressure relief valve	Page 82
<b>Vehicle identification</b>	<b>Page 83</b>
<b>Usage instructions for an LPG vehicle</b>	<b>Page 84</b>
Vehicle fire	Page 84
Traffic accident/gas outlet on a LPG vehicle	Page 85
Closing the LPG tank	Page 86
<b>BEV electric vehicles and PHEV hybrid vehicles</b>	<b>Page 87</b>
<b>Octavia Green E Line II electric car</b>	<b>Page 87</b>
Deactivating the high-voltage system and drive	Page 91
Deactivating the high-voltage system and drive from the inside	Page 92
Deactivating the high-voltage system and drive from the engine compartment	Page 93
<b>ŠKODA Citigo-e iV vehicle</b>	<b>Page 94</b>
Deactivating the vehicle's high-voltage system	Page 99
Deactivating the high-voltage system in the engine compartment	Page 99
Deactivating the high-voltage system in the vehicle interior	Page 99
Disconnecting the charging current supply	Page 100
<b>ŠKODA Superb PHEV Hybrid vehicle</b>	<b>Page 101</b>
Deactivating the vehicle's high-voltage system	Page 105
Deactivating the high-voltage system in the engine compartment	Page 105
Deactivating the high-voltage system in the vehicle interior	Page 105
Disconnecting the charging current supply	Page 106
<b>Special instructions and safety information for BEV electric vehicles and PHEV hybrid vehicles</b>	<b>Page 107</b>
Fire in the vehicle	Page 107
Vehicle in water	Page 109
Towing, transportation, storage	Page 111
<b>SCR system</b>	<b>Page 112</b>
Injection system for synthetic urea water solution - SCR	Page 112
Installation in vehicles	Page 112
ŠKODA Superb III vehicle	Page 112
AdBlue reducing agent for selective catalytic reduction - SCR	Page 113
<b>Emergency call</b>	<b>Page 114</b>
ERA-GLONASS emergency call system	Page 114
ERA-GLONASS emergency call system control element	Page 115
eCall emergency call system	Page 116
The ECall emergency call system operating element	Page 117
Location of the emergency call system control element	Page 117
<b>Air conditioning refrigerant</b>	<b>Page 118</b>
Information signs for the refrigerant circuit	Page 119
Notes	Page 120



# Guidelines for Rescue Services

## Search and rescue from crashed ŠKODA vehicles

These guidelines have been created exclusively for rescue teams, who have special training in the field of technical assistance for road accidents and can therefore carry out the activities described in this guide.

The vehicle range offered by ŠKODA, as well as the specifications and optional equipment available, are constantly changing in specific ways. Therefore, ŠKODA explicitly reserves the right to make adjustments or changes to these guidelines.

These guidelines are intended to assist emergency personnel to carry out their duties with the necessary information relating to the technology used in ŠKODA vehicles.

The information is particularly intended for education and training of emergency services.

Here, incidents of self-endangerment on the accident vehicle must be excluded as far as possible.

The necessary basic knowledge must be conveyed at this point.

### Please consider:

The information contained in these guidelines is not intended for end users, nor for workshops and dealers. End users can see the owner's manual of their respective ŠKODA vehicle for information about the features of their vehicle, as well as important safety information for vehicle and occupant safety. Workshops and dealers obtain repair information from known sources.

The demands on a vehicle are varied and also change over time. The safety of vehicle occupants is therefore becoming increasingly important due to the increasing traffic volume. More and more vehicles are equipped with ever improving safety technology.

This safety technology is divided into active and passive safety technology.

**Active** safety technology helps prevent accidents.

For example, using the anti-lock braking system (ABS), electronic differential lock (EDL) and electronic stabilization program (ESP or ESC).

**Passive** safety technology helps minimise possible consequences for the occupants.

This refers to vehicle components such as the safety body, the retractable steering column, as well as crumple zones. These vehicle safety components are designed with calculated deformation behavior. Passive safety elements include energy-absorbing bumpers, seats and side impact protection,

This includes all the vehicle's safety-related components, which are only activated on impact – seat belts with belt tensioners, and all airbag systems.

The integrated safety elements in today's vehicles support the passive safety elements with active safety systems – e.g. the integrated safety systems, "**City Safe Drive**" - **active brake assist**, are activated as a result of an emergency braking function.

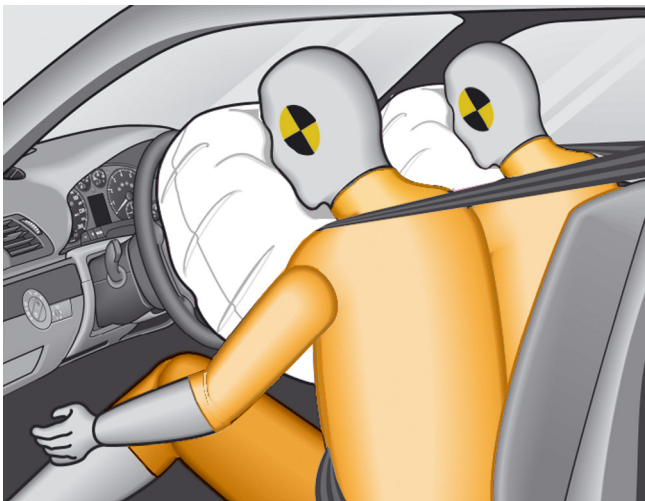

SRB\_010



These guidelines include the emergency sheets to be stored in the emergency vehicle. Both must be read carefully by the rescue personnel in order to provide the necessary knowledge for working on ŠKODA brand vehicles.

# Battery and its disconnection, battery disconnection element

## Battery

All standard ŠKODA vehicles currently have a vehicle battery.

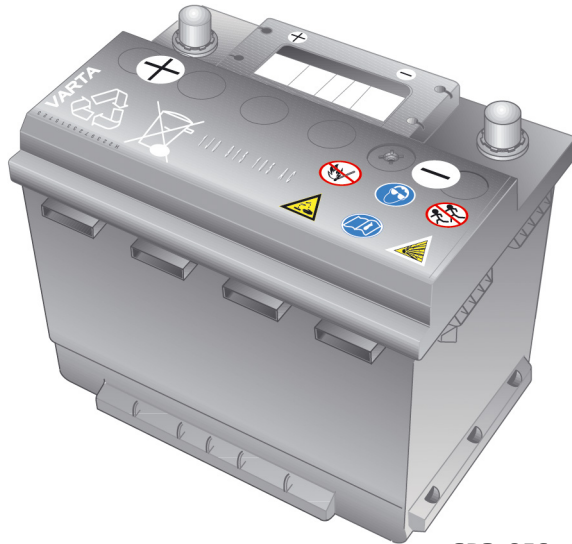

SRB\_056

The battery is located in the engine compartment for all ŠKODA vehicles.



However, this does not apply to the Superb II vehicle with the 3.6 l / 191 kW FSI engine, where the battery is located on the left side of the trunk, as well as to the Rapid vehicle with the 1.6 l / 85 kW TDI CR engine, where the battery is located in the spare tire well under the trunk floor. These vehicles are also equipped with a pyrotechnic element for separating the starter cable from the battery.



The respective vehicle-dependent installation location of the battery in ŠKODA brand vehicle models can be found in the data sheets.

## Pyrotechnic element for separating the starter cable from the battery for Superb II vehicles with the 3.6 l/191 kW FSI engine

The purpose of this separator is to disconnect the starter cable from the vehicle battery. This is done using a pyrotechnic igniter. The battery separator is activated together with the airbags or belt tensioners.

1. Connecting the battery positive terminal
2. Release pin
3. Igniter

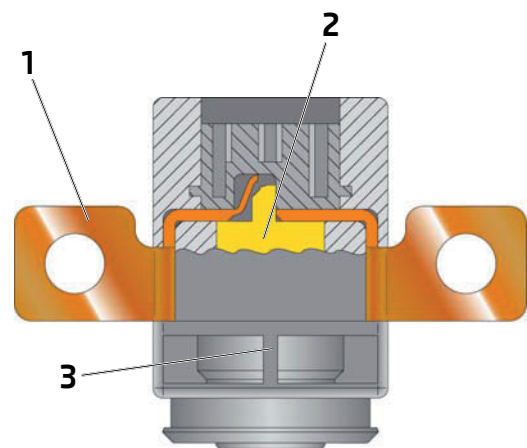

410\_123

## Notes on disconnecting the vehicle battery



At the beginning of rescue work on a vehicle, the battery's negative terminal (earth) and positive terminal must be disconnected. Since all Škoda brand vehicles have an electric ignition system, they can not be tripped when the voltage supply is interrupted. Likewise, electrically triggered belt tensioners can also no longer be activated. However, **note** the following information:



The airbags and belt tensioners are deactivated in max. 4 seconds after disconnecting the earth connection. Before this time has elapsed, there is a risk of the airbag being triggered as a result of possible damage to the airbag system. In individual cases, the airbags and belt tensioners may also be triggered after this time due to an electrostatic charge.



In some ŠKODA brand models produced earlier, such as the Felicia, Fabia I and Octavia I, belt tensioners were mechanically triggered. This was controlled independently of the vehicle's supply voltage. These belt tensioners cannot be disabled by disconnecting the battery.



Due to poor access or a lack of time, the battery can be disconnected by disconnecting the connection cable. **If the battery cannot be disconnected, injured persons must always be supplied outside the deployment area of the airbag. There is always a corresponding safety distance to the airbags**

!

The vehicle battery can be disconnected in accordance with the following flowchart:

1. Preventing the vehicle from rolling away
2. Switch off the running vehicle engine (ignition)
3. Turn on hazard warning lights
4. Use electrical equipment to be used for rescue
5. Locate and disconnect the battery
6. Check there is no voltage

### 1. Preventing the vehicle from rolling away

Secure the vehicle from the outside, e.g. use wedges to prevent vehicle rolling away.

Secure the vehicle from the inside using the handbrake.



SZ1-0003

For vehicles with automatic transmission, move the selector lever to position "P".



SZ1-0004



## 2. Switch off the running vehicle engine (ignition)

The vehicle's running engine must be switched off.  
Switch off the engine using the ignition key.



SZ1-0005

Optionally, some models can be fitted with a keyless entry and start authorisation system. Switch off the engine by pressing the start/stop button.

By switching off the ignition, the voltage supply to the airbag control unit is interrupted. It is no longer possible to electrically trigger the airbags and belt tensioners after a maximum of 4 seconds. In doing so, the following instructions must be observed > Page 9.



Depending on the vehicle type and construction year, the fuel pump is switched off by the airbag control unit in the event of an accident. The running engine is therefore switched off.



In the case of vehicles with an automatic transmission, the selector lever must be put in the "P" position to be able to remove the ignition key.

## 3. Turn on hazard warning lights

If the hazard warning lights are turned on, they provide all emergency personnel with a visual sign that the vehicle's power supply is active.



Depending on the vehicle type and construction year, the hazard warning lights are automatically turned on by the airbag control unit in the event of an accident.

## 4. Use electrical equipment to be used for rescue

Depending on the model and vehicle equipment, ŠKODA brand vehicles feature a whole range of electronic convenience systems, e.g.:

- electric windows
- electric sunroof
- electric seats
- electric trunk lid



After disconnecting the battery, these systems can no longer be operated. This should be noted when opening the luggage compartment.



Where possible, the convenience electronics should be used before disconnecting the battery to benefit the rescue work!



The battery should only be reconnected to the electrical system by workshop personnel.

## 5. Locate and disconnect the battery

In parallel with the previous measures, the battery should be located.

For all ŠKODA brand vehicles, **the battery is in the engine compartment** except for the Superb II vehicle with the 3.6 l / 191 kW FSI engine as well as the Rapid vehicle with the 1.6 l / 85 kW TDI CR engine.

On the Superb II with the 3.6 l / 191 kW FSI engine, the battery is located on the left side of the trunk.

In the case of the Rapid vehicle with the 1.6 l / 85 kW TDI CR engine, the battery is located in the spare tire compartment under the trunk floor.



The respective vehicle-dependent installation location of the battery in ŠKODA brand vehicle models can be found in the data sheets.



To access the bonnet or luggage compartment, there are several conventional methods of opening available (bonnet release, ignition, etc.). If this does not work, the bonnet or luggage compartment flap can be opened by force using a crowbar or hydraulic spreader.



The battery splitter element for the Superb II with the 3.6 l / 191 kW FSI engine and the Rapid with the 1.6 l / 85 kW TDI CR engine only separates the positive battery line to the starter > Page 8. Other vehicle systems, such as the hazard warning lights, interior lighting and safety systems remain functional. **This means the battery must be disconnected anyway.**

When disconnecting the battery, first disconnect the battery's **negative pole terminal (earth)** And then the positive terminal .



Example for locating and disconnecting the battery earthing strap in the engine compartment.



SZ1-0006



Locating and disconnecting the battery earthing strap on the Superb II with the 3.6 l/191 kW FSI engine to the left in the luggage compartment.



SZ1-0036

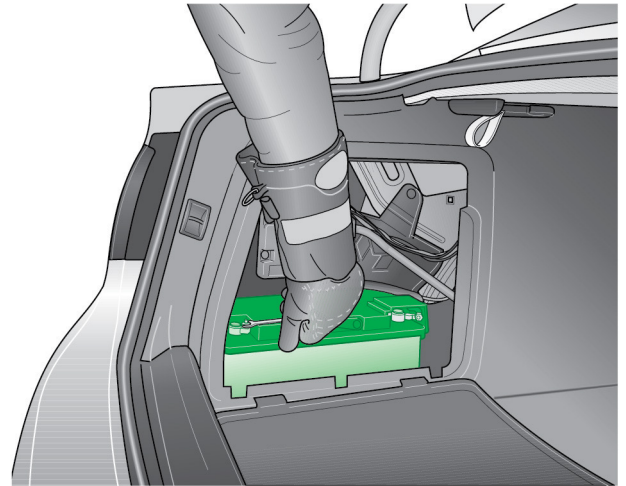

SZ1-0037



Localization and disconnection of the battery grounding tape in the Rapid vehicle with the 1.6 l/85 kW TDI CR engine in the spare tire trough under the trunk floor.



SZ1-0046

## 6. Check there is no voltage

If the battery is disconnected, check whether the vehicle is actually de-energised. If the hazard warning lights or interior lighting switch off, this may be an indicator.

# Airbag

Depending on the model and equipment variant, vehicles can be equipped with different numbers of airbags. The airbag system is controlled by the airbag control unit with integrated sensors. On the controller, external sensors are also connected using a wiring harness, e.g.:

- Acceleration sensor on the vehicle front
- Pressure sensors on the front doors
- Acceleration sensors in the C-pillar

The electronics integrated in the airbag control unit have the task of detecting the vehicle deceleration or vehicle acceleration, and of recognising whether it is necessary to trigger the protective systems. In addition to the internal sensors in the control unit, there are also external sensors. Only once the information from all sensors has been evaluated will the electronics in the airbag control unit decide whether or when which safety components are activated. Depending on the type and severity of the accident, only the belt tensioner is triggered, or the belt tensioners together with the airbag, for example.



The airbag control unit is identified in the rescue datasheets as follows:

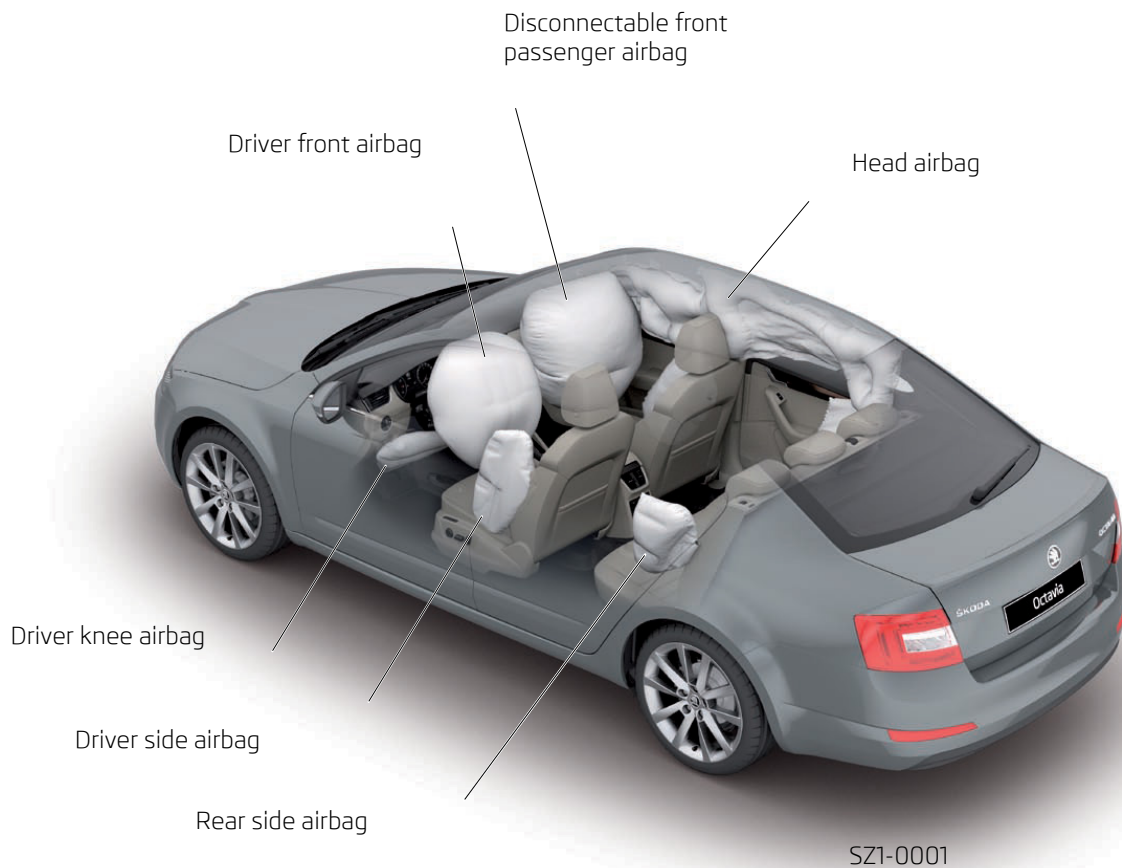
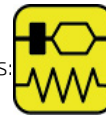

The front passenger airbag can be switched off using a key switch, which is located on the instrument panel near the glove compartment or nearby.



To illustrate the technical description, the Octavia III was used.

## Overall view of the airbag system

In the figure, the following components are displayed in colour:

**Red:** all airbag units

**Green:** Airbag control unit and external sensors

**Blue:** Automatic belt retractor

The automatic belt retractor on the front seats are equipped with belt tensioners. In addition, these can be equipped with the PCB system that fixes and then releases passengers on the front seats by tightening the reversible belts.

## Airbag control system

Airbag system in the Octavia III model.

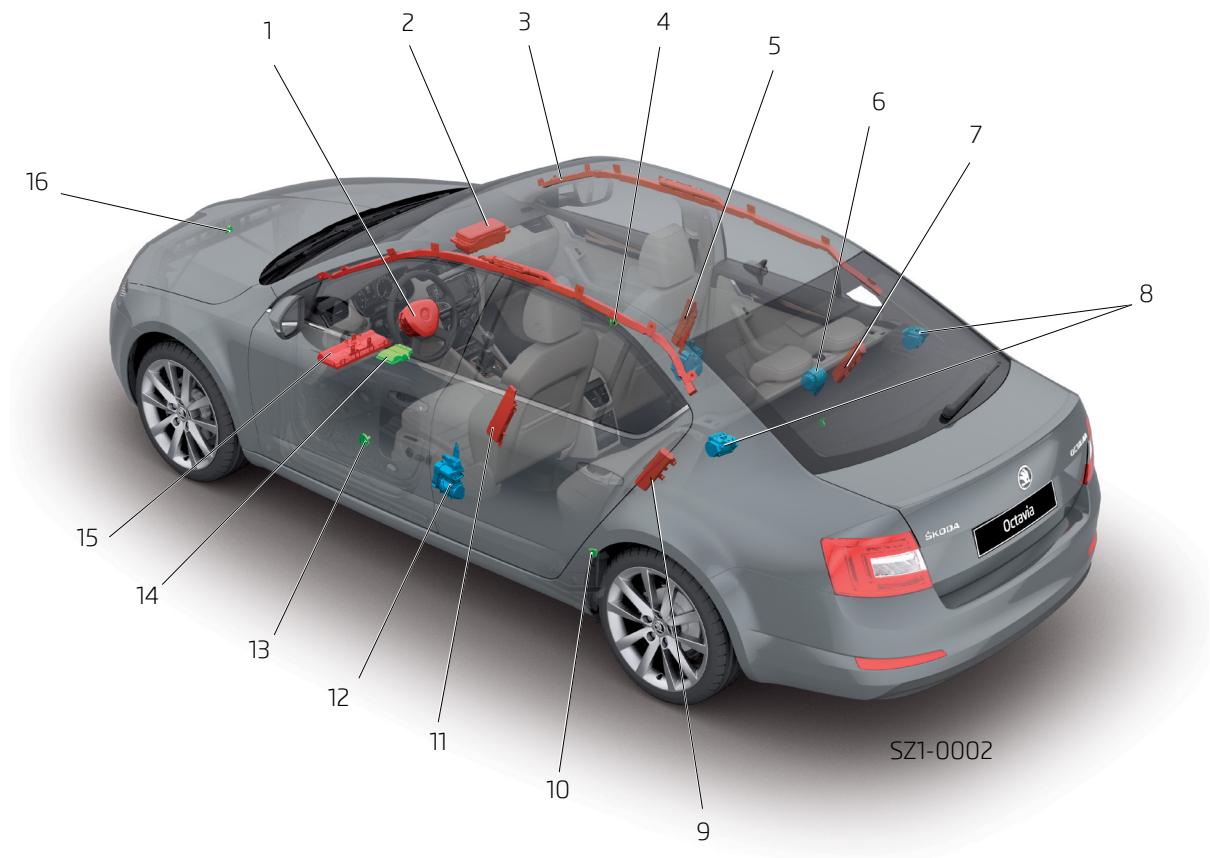

1. Driver front airbag unit, installed in the steering wheel centre
2. Front passenger airbag unit, installed under the instrument panel
3. Side airbag bar for right seats, installed under the roof lining
4. Pressure sensor in the passenger door
5. Passenger side airbag unit, integrated in the outer side of the seat back
6. Automatic belt retractor for the rear middle seat without belt tensioner
7. Side airbag unit, rear right, installed under the C-pillar trim
8. Automatic belt retractor for rear outer seats without belt tensioners
9. Side airbag unit, rear left, installed under the C-pillar trim
10. Acceleration sensor in the lower region of the left C-pillar
11. Driver side airbag unit, integrated in the side of the seat back
12. Automatic belt retractor with pyrotechnic belt tensioner and the Pre Crash Base system
13. Pressure sensor in the driver's door
14. Airbag control unit in the centre tunnel of the vehicle floor
15. Driver knee airbag unit, installed under the lower section of the instrument panel
16. Acceleration sensor



# Airbag deployment

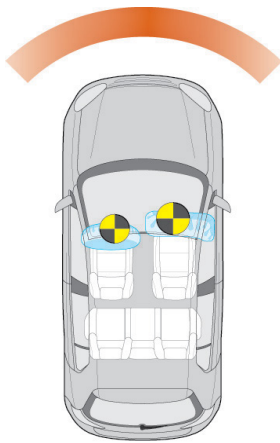

r1f\_2010\_002

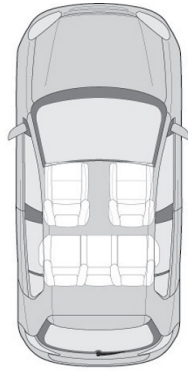

r1f\_2010\_003

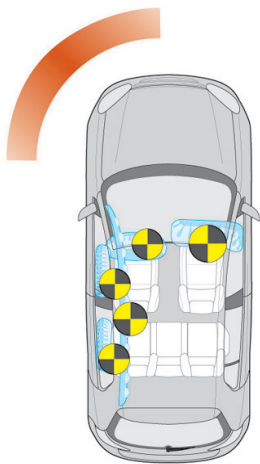

r1f\_2010\_004

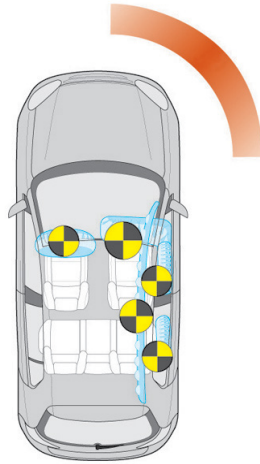

r1f\_2010\_005

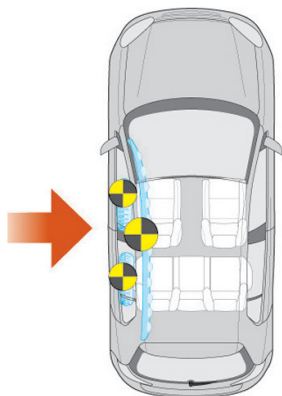

r1f\_2010\_006



r1f\_2010\_007

The control unit decides to trigger the relevant airbag using a programmed algorithm that evaluates signals from external sensors, and also signals from the sensors integrated in the control unit.

The basic conditions include both front airbags and knee airbags being triggered in a frontal impact, and the side airbags being triggered together with the head airbag in a side impact. If the vehicle is not equipped with head airbags, only the side airbag is triggered.

Furthermore, the pyrotechnic belt tensioners are always triggered together with the airbag. In the event of side accidents, belt tensioners and airbags are only triggered on the relevant impact side.

Besides the main function of controlling the airbag, the airbag control unit also performs other functions if the airbag is triggered such as:

- Emergency unlocking of the central locking system
- Switching on the interior lighting
- Switch off the fuel pump
- Turning on the hazard warning lights

Inflators produce the required amount of gas to fill the airbags after being triggered and therefore inflate the airbags. The inflated airbags protect belted occupants in a severe accidents before they impact on the internal body contours.

Depending on the installation location and requirement, inflators are available in various designs and with different operating principles.

## Schematic figure for belt tensioner and front airbag timing in a frontal accident

- 0 ms** Collision - the vehicle touches the crash wall.
- approx. 15 ms** The airbag control unit activates the driver airbag and the driver airbag begins to inflate.
- approx. 20 ms** The airbag control unit activates the passenger airbag and the passenger airbag begins to inflate.
- approx. 50 ms** The driver airbag is fully inflated and the driver plunges into the airbag.
- approx. 60 ms** The passenger airbag is fully inflated and the passenger plunges into the airbag.
- approx. 80 ms** The driver has fully plunged into the airbag and starts to move away from the steering wheel again.
- approx. 100 ms** The passenger has fully plunged into the airbag and also starts to move backwards again.
- 150 ms** The driver and front passenger to move back into their seats and airbags are both largely emptied. The view forwards is unobstructed.

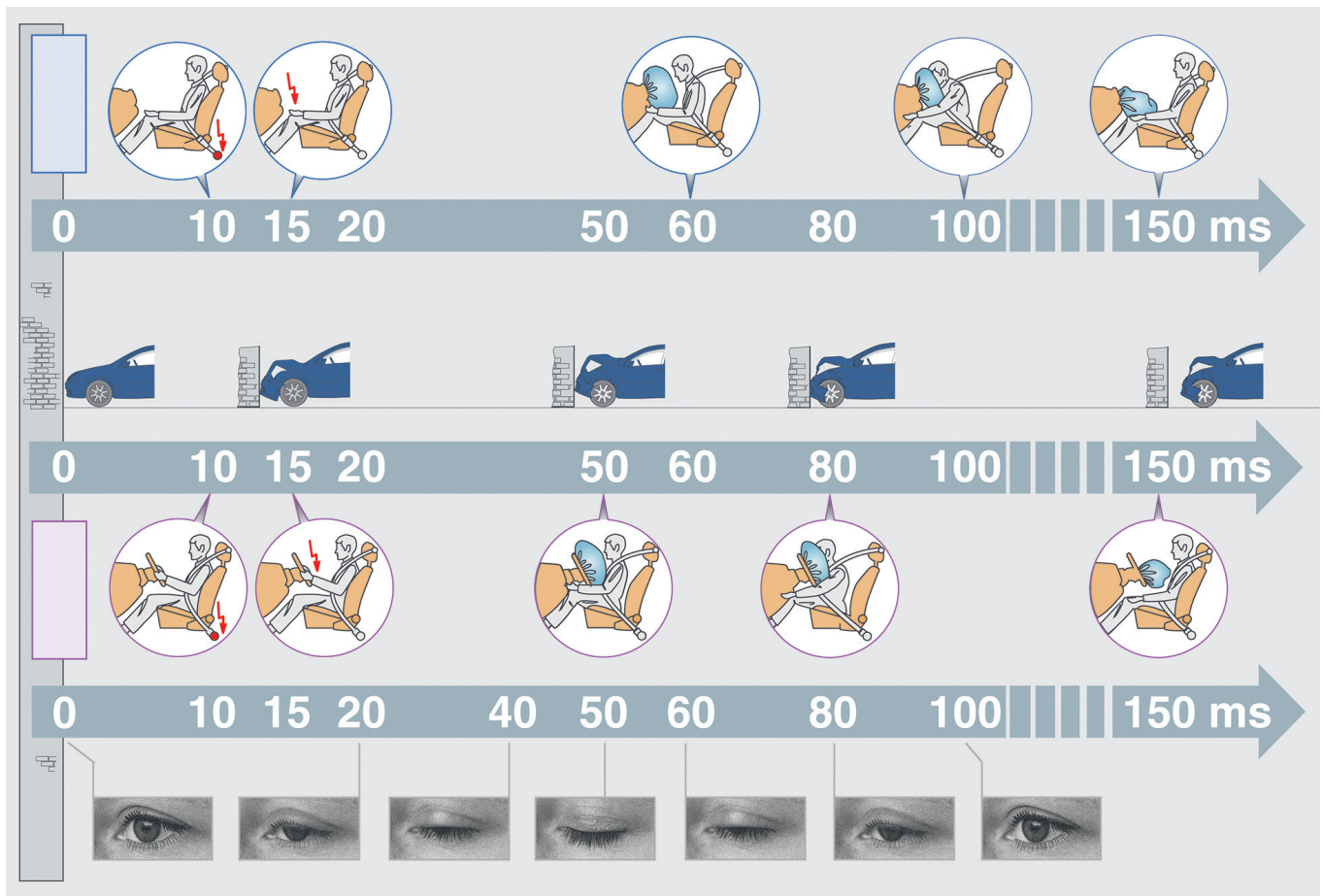

rif\_2010\_008



The figure shows the basic timing when the front airbag is triggered. There may be differences depending on the vehicle model.



# Front airbags

## Driver airbag

The driver airbag unit consists of a cover cap, an airbag and an inflator. It is fixed in the steering wheel and electrically connected to the airbag control unit. Its size and shape is designed so that it forms a protective barrier between the driver and steering wheel after it has been inflated.

An inflator inflates the driver airbag, and it is actuated by an igniter that is activated by the airbag control unit. When the solid propellant is being combusted, the airbag fills with resulting filling gas. Due to rapidly rising pressure, the plastic cover snaps at the defined tear line and the airbag opens. The airbag deployment area is determined. The torn plastic cover remains on the airbag unit. This means that it is not torn off and thrown out.

Using limiting straps on the inside of the airbag, it is ensured that the bag actually comes into the desired shape.

The airbag fabric is made of polyamide. Thanks to outlet openings on the side facing away from the driver, the kinetic energy that is generated when the upper body plunges into the airbag is compensated by the filling gas being released evenly.



Plastic cover

Airbag

Inflator with metal filter



The gas with which the airbags are filled when inflated is not dangerous for the occupants. Before the filling gas flows from the inflator into the airbag, it is cleaned and cooled by the metal filter. The design of the driver airbag may be different depending on the vehicle.

## Passenger airbag

The airbag unit for the passenger is located in the instrument panel in front of the passenger seat. Since a larger free space between the passenger and the airbag unit must be covered on the passenger side, the volume of the airbag is much larger than on the driver's side. The cover of the passenger airbag is located in the instrument panel, either as an integrated component or as part of a specially designed area with partly invisible predetermined tear lines. After triggering the airbag, the filling gas originating from the corresponding openings flows from the inflator into the folded airbag, and begins to inflate it. The bag expands quickly. The instrument panel cover rips or folds in accordance with defined tear lines and the bag unfolds completely. Both solid propellant inflators and hybrid inflators are used to inflate the passenger airbag.

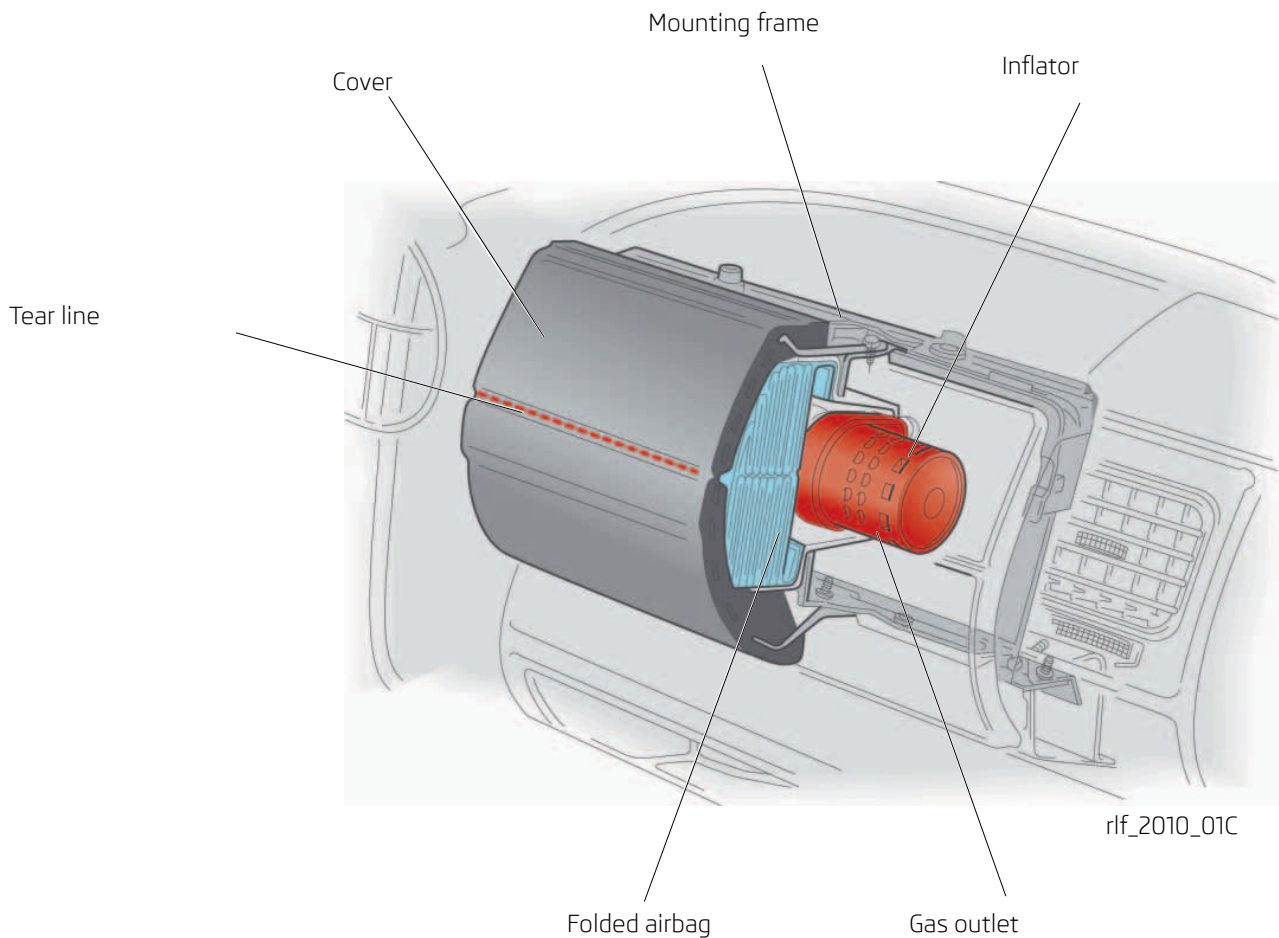

There must be no cutting, etc., in the area around the inflators.



The pictorial representation is in principle. However, the design may be different depending on the vehicle.

## Knee airbag

The knee airbag is installed underneath the dashboard in the driver's footwell. In the event of an impact, this prevents contact between the legs and the parts of the dashboard, and parts below the dash panel.

The knee airbag is always triggered together with the driver airbag, and reduces the risk of injury in the knee and leg area. It prevents the body from slipping under the instrument panel and provides further support to improve other restraint systems. Since the knee contact area with the airbag is minimal, the knee airbag is designed to be considerably harder. Unlike the front and side airbags, no gas will escape here. To avoid gas leakage from the airbag, the inside of the knee airbag is coated with silicone.

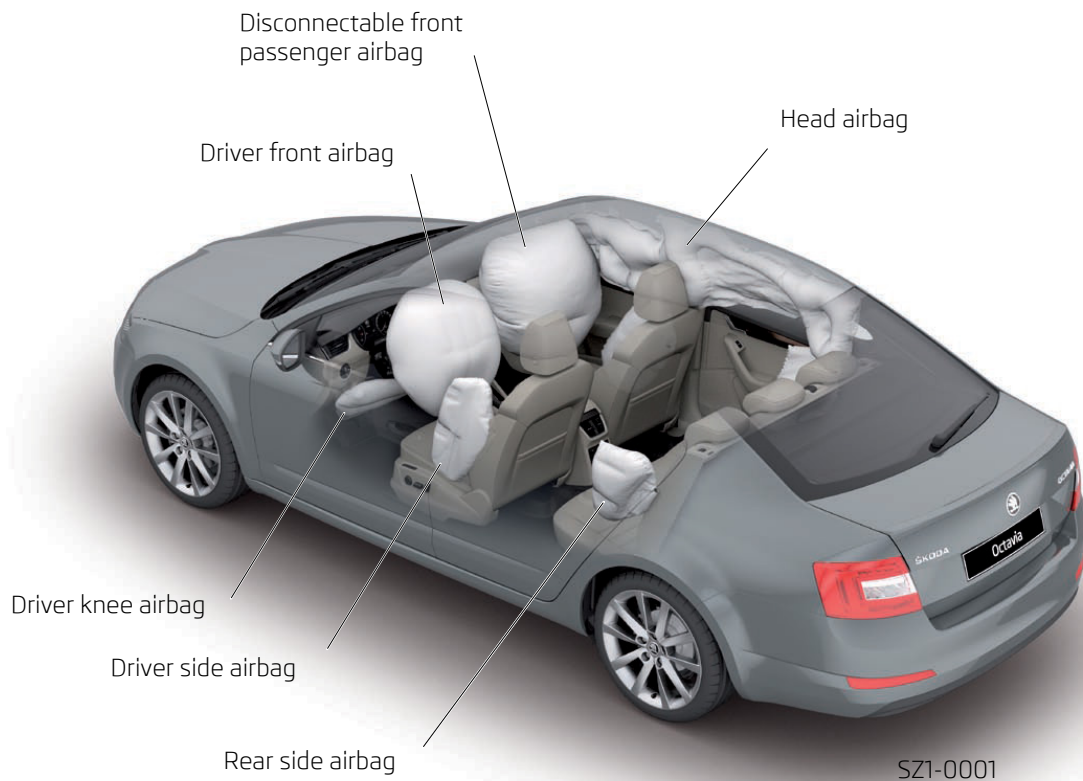

## Head airbag

The head airbag is designed to protect the head in the event of a side impact. There is a shared airbag for the front and rear seats. Unlike front and side airbags, the head airbag may maintain its internal pressure for some time after triggering in order to provide further protection if the vehicle subsequently rolls over or is involved in secondary collisions. For the head airbags, tubular inflators are used. Due to the particularly narrow installation position, these inflators are very slim.

## Side airbags

In the event of side-impact accidents, the side airbag protects passengers' pelvises on the impact-side of the vehicle. It is positioned laterally between the upper body and invading trim parts, and distributes the impact more evenly over the occupants, which is closely linked to the intrusion movement.

The side airbag is located in the seat backrest of the driver's and passenger's seat. This ensures that a constant distance from the occupants is maintained in every seat position. In addition, it may be installed in the rear quarter panel. To inflate the side airbags, solid propellant inflators or hybrid inflators are used.



The pictorial representation is in principle. However, the design may be different depending on the vehicle.

## Head/thorax airbag

The side airbags that protect the driver's and passenger's head and thorax are always integrated into the backrests of the front seats. It protects the driver's and front passenger's head and chest in the event of a side impact. The structure and function is similar to that of a side airbag. It extends from the passengers' chest to the head.



SP92\_43



The picture shows the triggered head / thorax airbag in the vehicle.



Airbags are indicated in the rescue datasheets as follows:



# Airbag inflators

## Solid propellant inflators

The solid propellant inflators consist of a housing, in which a solid propellant kit is integrated with an ignition unit. The structure and form of the inflator housing is adapted to installation conditions in each case. Inflators are distinguished by their design, e.g. divided into round inflators and pipe inflators.

The solid propellant is generally used in tablet or ring shape. After igniting the solid propellant, filling gas that is safe for the vehicle occupants is released. If the airbag control unit receives the corresponding crash information from the crash sensor, it activates the igniter, which ignites the solid propellant. It causes the fuel to be burned quickly. This produces the airbag filling gas, which consists of nitrogen compounds and carbon dioxide. The gas flows through the metal filter, where it is purified and cooled. Subsequently, it flows through the outlet openings of the inflator into the folded airbag and inflates it.

### Application:

Driver front airbag and side airbags.

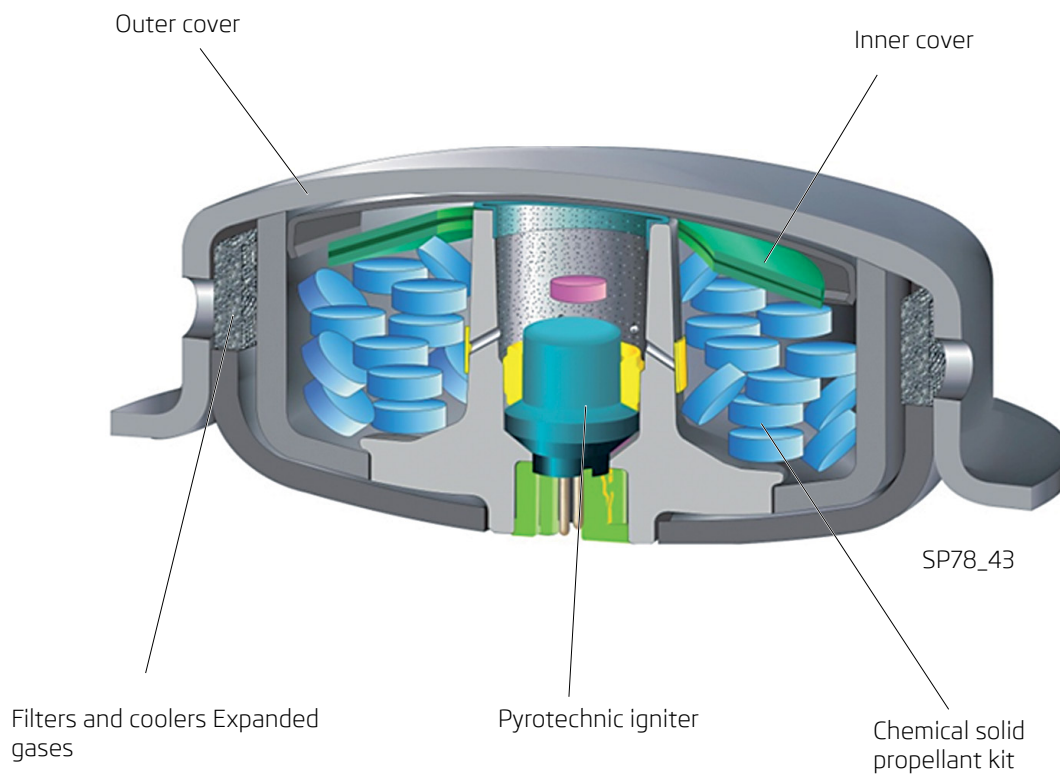

The gas with which the airbags are filled when inflated is not dangerous for the occupants. Before the filling gas flows from the inflator into the airbag, it is cleaned and cooled by the metal filter.



Do not damage the inflators during rescue work. Gas and pyrotechnic fuels may be a potential danger for rescuers and passengers.



## Hybrid inflators

Hybrid inflators consist of a housing, in which a compressed gas stored under high pressure and a solid propellant are combined with an ignition unit. The structure and form of the inflator housing is adapted to installation conditions in each case. Most of these inflators are tubular.

The main components are the pressure vessel with the airbag filling gas and the propellant charge that is integrated in the pressure vessel or bottled beside it (solid propellant). The stored and compressed gas is a mixture of inert gases, such as argon and helium. Depending on the design of the inflators, it is at a pressure of 20 MPa (200 bar) and 60 MPa (600 bar).

If the airbag control unit receives the corresponding crash information from the crash sensor, it activates the igniter, which ignites the solid propellant. After the pressure increases, the rupture disc is broken by the hollow sliding piston and the compressed gas flows into the combustion chamber.

The hot gas, which is produced by burning the solid propellant, mixes with the gas that is flowing from the pressure vessel and heats it up. As a result, the escaping gas can expand faster.

The gas mixture flows through the corresponding openings on the metal filter in the inflator into the airbag and inflates it. Inflators can be fitted with an additional outlet opening that allows the filling gas to flow into the atmosphere and not into the airbag after a defined time. This allows the airbag to be adapted to the accident.

### Application:

Front passenger airbag, knee airbag, head airbags, except the ŠKODA Yeti.

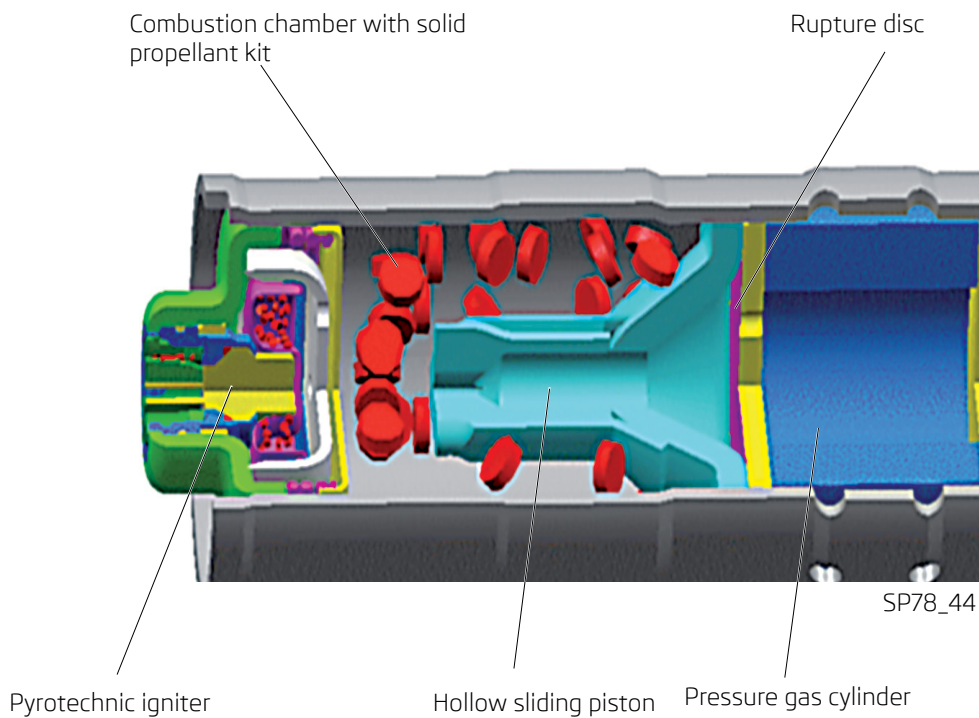

The gas with which the airbags are filled when inflated is not dangerous for the occupants. Before the filling gas flows from the inflator into the airbag, it is cleaned and cooled by the metal filter.



Do not damage the inflators during rescue work. The compressed gas in the pressure vessel and the pyrotechnic fuels may be a potential danger for rescuers and passengers.

## Inflators

The head airbag in the ŠKODA Yeti vehicle is fitted with an inflator that contains a single compressed gas cylinder (helium + argon), in comparison with the hybrid system. This gas mixture flows into the airbag when a signal is received from the control unit.



SP78\_101



Do not damage the inflators during rescue work. The compressed gas in the pressure vessel may be a potential danger for rescuers and passengers.

## Gas springs

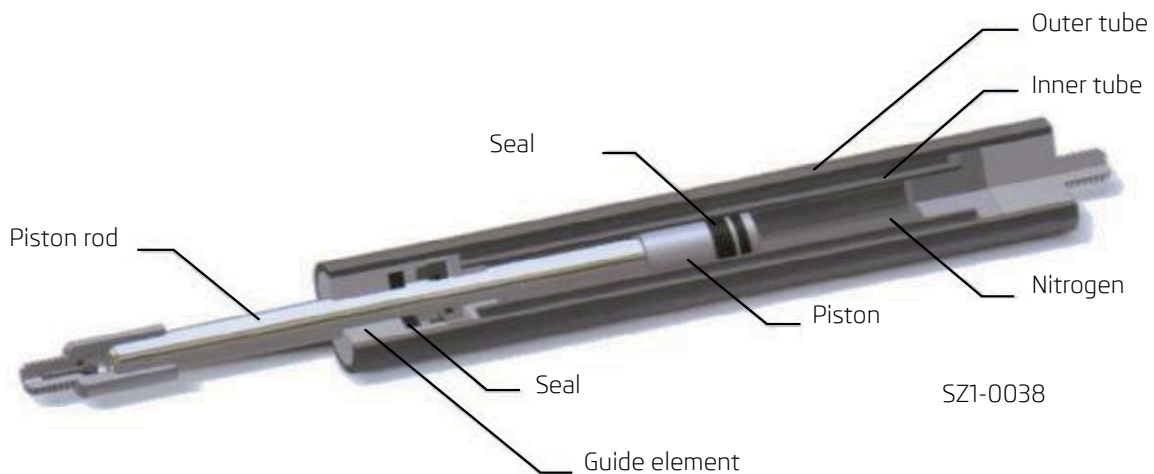

SZ1-0038



Do not damage the gas springs during rescue work! The highly compressed nitrogen in the gas spring may be a potential danger for rescuers and passengers.



## Identification of the airbag in the vehicle

All airbag module is marked with the wording "AIRBAG". The marking is usually on the airbag module or in its vicinity. For the side airbags fitted in the seat backrests, the marking may also be on a label sewn into the cover of the seat back.

In the overview, the position marked "AIRBAG" is shown through examples.

### Driver front airbag

The "AIRBAG" marking for the driver front airbag can be found on the steering wheel cover.



SZ1-0018

### Front passenger airbag

The "AIRBAG" marking for the passenger airbag can be found on the right instrument panel.

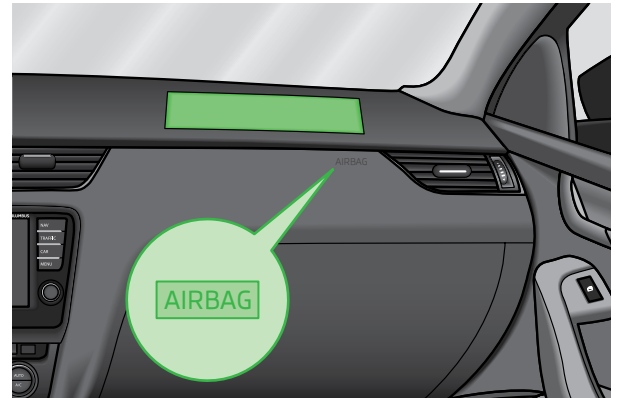

SZ1-0019

### Front side airbag

The "AIRBAG" marking for the front side airbags can be found on the outer sides of the front seat backrests.



SZ1-0020

### Rear side airbag

The "AIRBAG" marking for the rear side airbags can be found on the outer sides of the rear seat backrests.



SZ1-0021

### Head airbag

The "AIRBAG" marking for the head airbags can be found on the A-, B- and C-pillar trim, depending on the vehicle type.

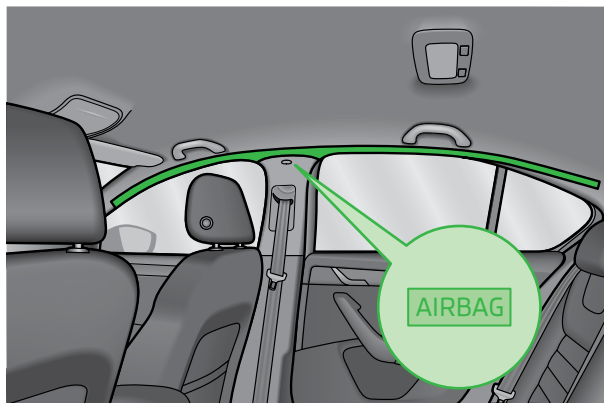

SZ1-0022

### Knee airbag

The "AIRBAG" marking for the knee airbag can be found on the side instrument panel cover on the driver side.

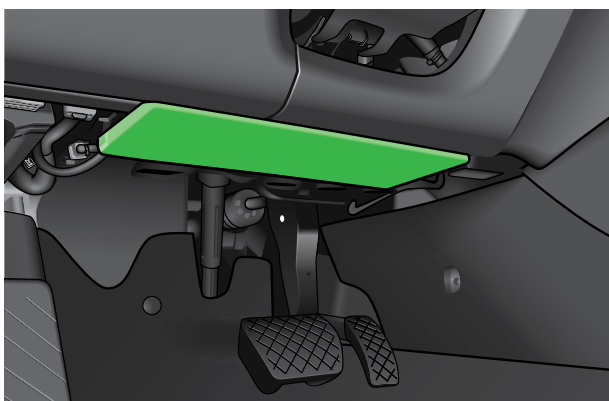

SZ1-0023

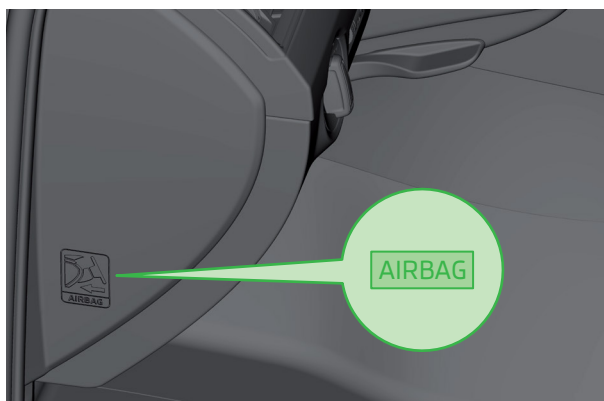

SZ1-0024

### The airbags' effective ranges

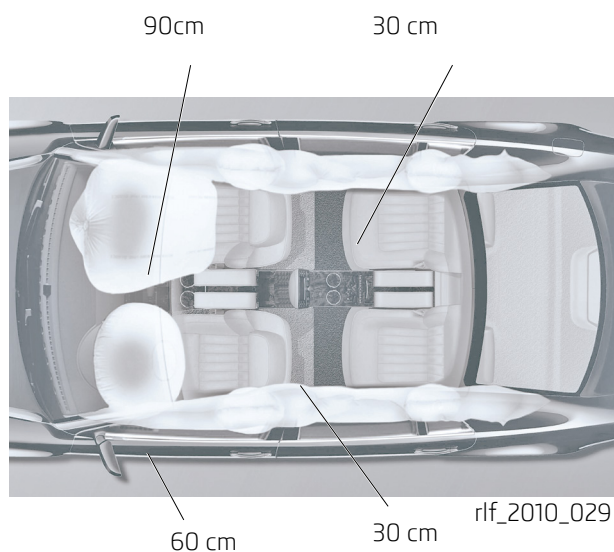

The effective ranges for non-triggered security systems should be kept clear.

# Belt tensioners

In a crash, belt tensioners wind the strap against the tension direction of the belt and the slack is reduced. As a result, passengers are already prevented from moving forwards at an early stage (relative to the movement of the vehicle). A belt tensioner is able to wind up approx. 200 mm of the seat belt within approx. 10 ms. If the force acting on the seat belt counterforce is greater than the force of the belt tensioner, the belt is no longer tensioned.

The belt tensioner system is triggered as follows:

- Mechanically
- Electrically

The belt tensioners are integrated within the harness system. However, they may be installed differently, depending on the vehicle type.

The belt tensioners can be installed at the following locations:

- In the B-pillar
- In the sill next to the seat
- On the outer side of the rear seat

## Example of a belt tensioner being deployed

The ball belt tensioner consists of a compact unit, which is driven by balls. The balls are mounted in a supply pipe. In the event of a crash, the propellant charge is ignited by a triggering unit. If belt tensioners are electrically triggered, the trigger unit is activated by the airbag control unit.

If the propellant charge is ignited, the balls are set in motion and start rotating the gearwheel. The gearwheel is fixed to the belt reel, which rolls up the seat belt (tightens). The balls that were driven by the gearwheel are caught in the ball catcher.

If belt tensioners are mechanically triggered, the propellant charge ignites as a result of the generator impact on the tappet. It may be triggered by shock or vibration, regardless of the battery voltage.

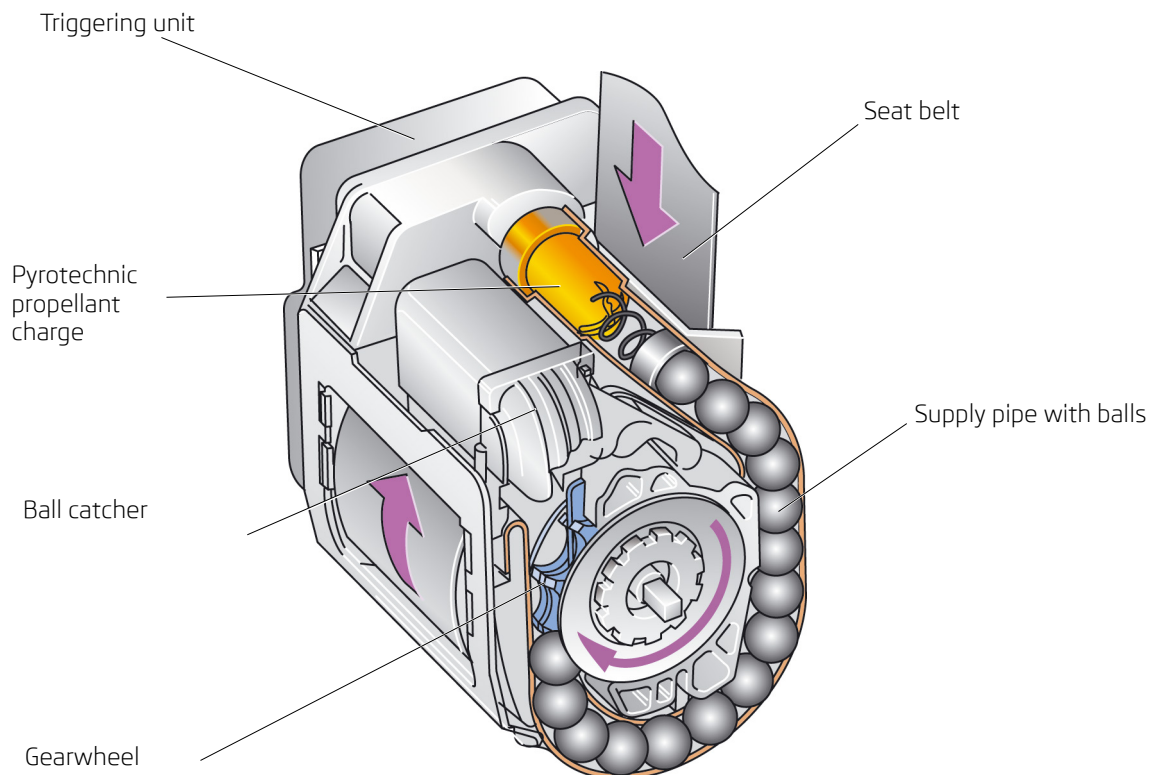

SRB\_073



The seat belt should, if the situation allows, be removed or cut away as soon as possible.



The belt also locks if the vehicle is heavily inclined, lying upside down or if the belt tensioner may have been damaged by the accident.



Belt tensioners should therefore not be damaged using cutting equipment, if possible. Avoid pounding in this area.



Mechanically triggered belt tensioners that have not been triggered may still trigger, even after disconnecting the battery.



Belt tensioners are indicated in the rescue datasheets as follows:



Belt tensioners

# Belt force limiters

So that the belt force does not exceed a certain level that may cause pelvis and chest injuries when restraining the body, the belt is equipped with a belt force limiter. This prevents the defined value from being exceeded. The clamping force is limited by a torsion shaft which is located in the belt reel and has a similar role to the spring.

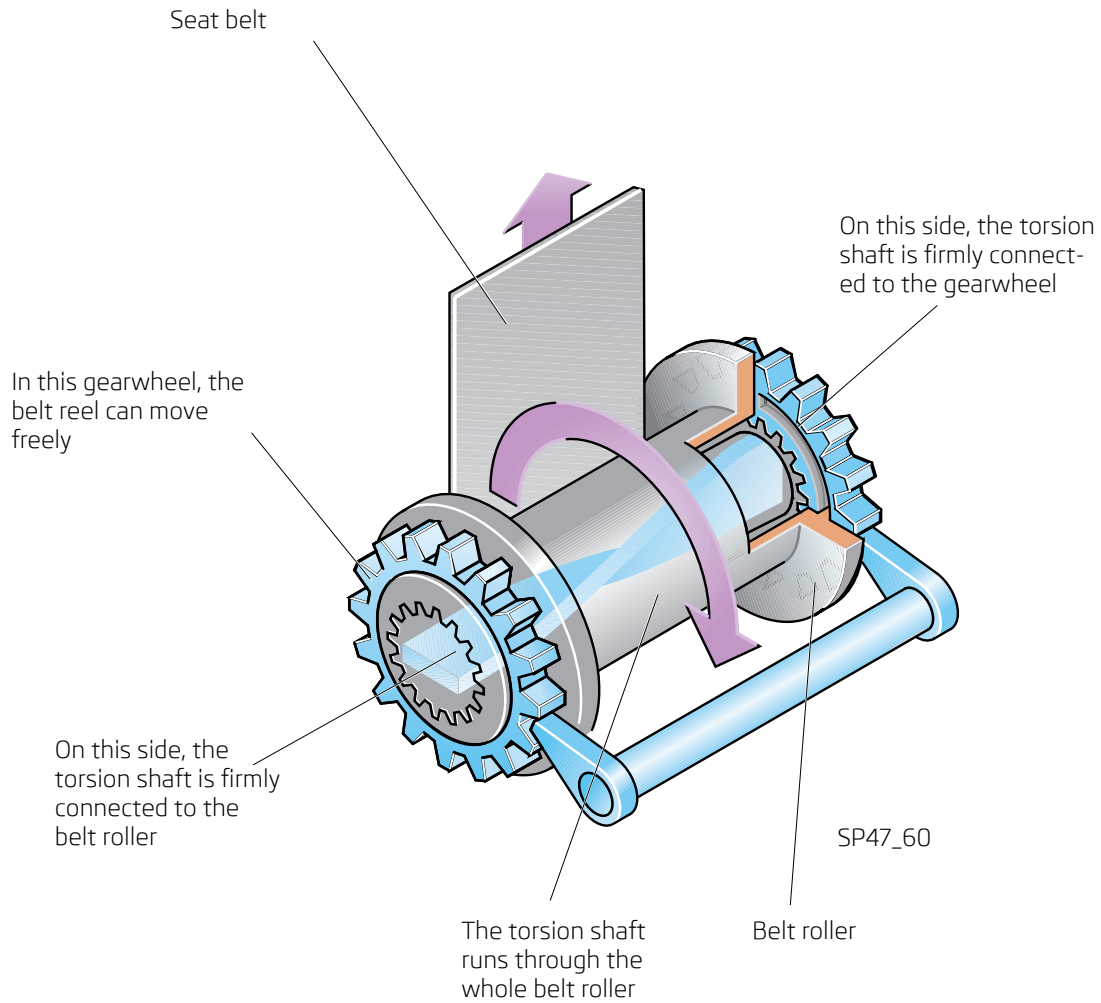

# Belt tensioner variants

## Cylindrical belt tensioners

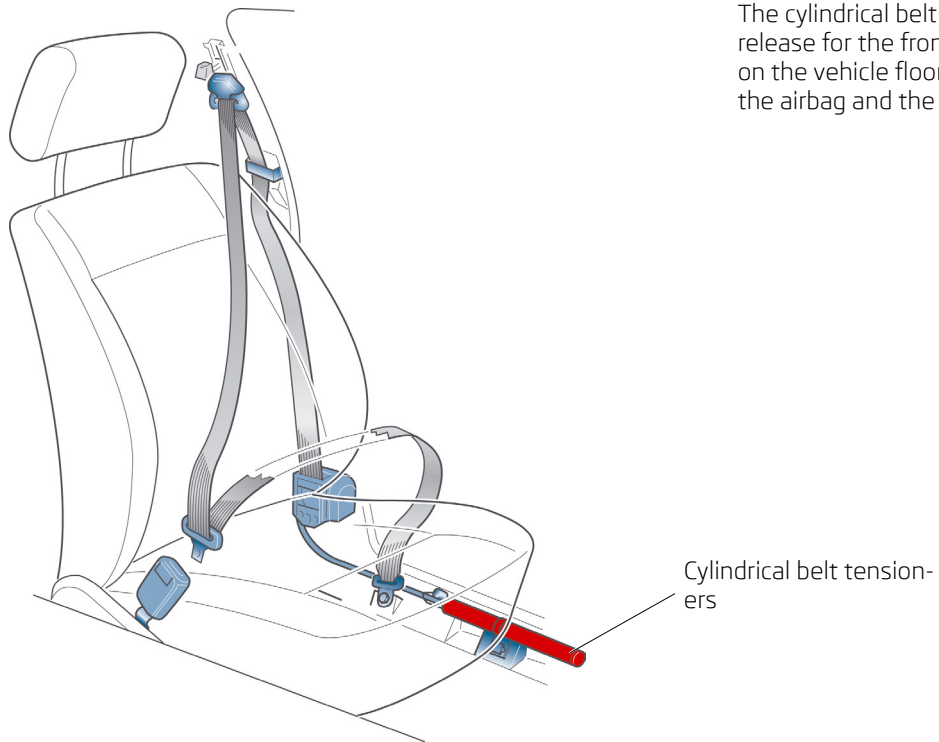

The cylindrical belt tensioner with mechanical release for the front seat is installed separately on the vehicle floor. It is triggered independent of the airbag and the battery voltage.

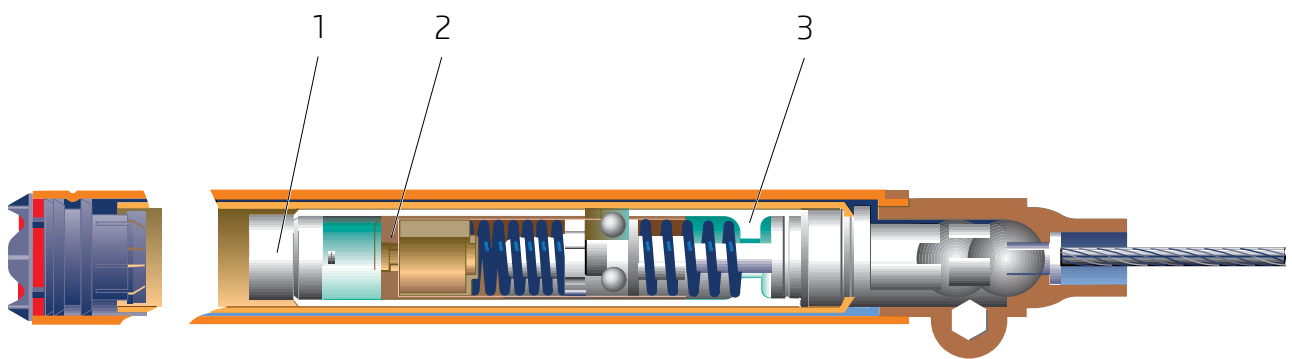

SP6-21

In the event of a vehicle accident, inflator **2** is triggered and breaks through pin **1**. As a result, the propellant charge is triggered and the resulting gas pressure moves piston **3** forwards. The piston is connected to the automatic belt retractor via a cable.

## Rack belt tensioners

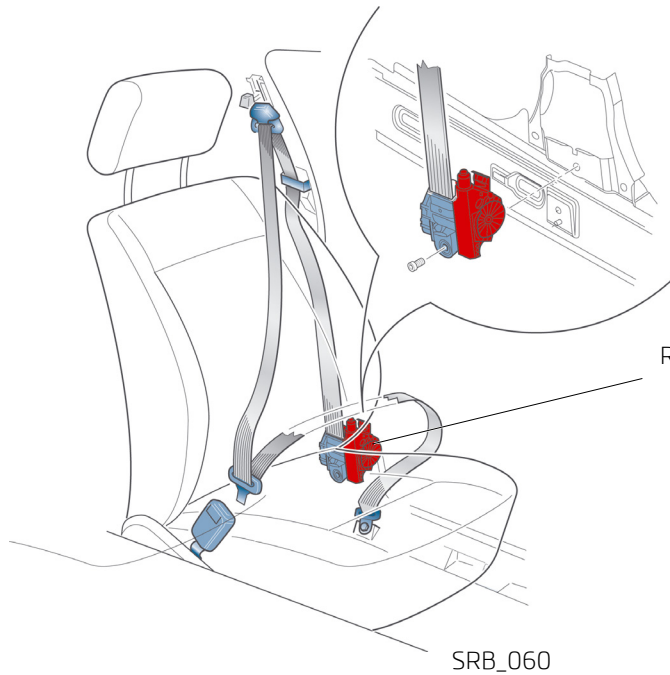

The toothed belt tensioner with electrical release is integrated in the belt retractor for the front seat.

Rack belt tensioners

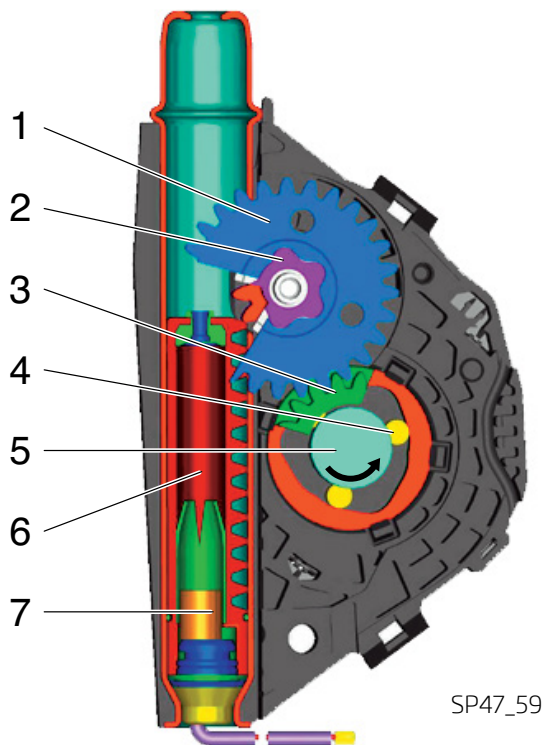

The igniter ignites the pyrotechnic propellant charge **7**.  
 The propellant charge creates pressure in the cylinder of piston **6**.  
 Piston **6** is engaged with gearwheel **2**, and it is connected to gear **1**.  
 Gearwheel **1** is engaged with gearwheel **3**. The rollers **4** start moving, wedge the shaft **5** and therefore initiate the rotary movement.  
 The seat belt is tightened.



## Ball belt tensioners

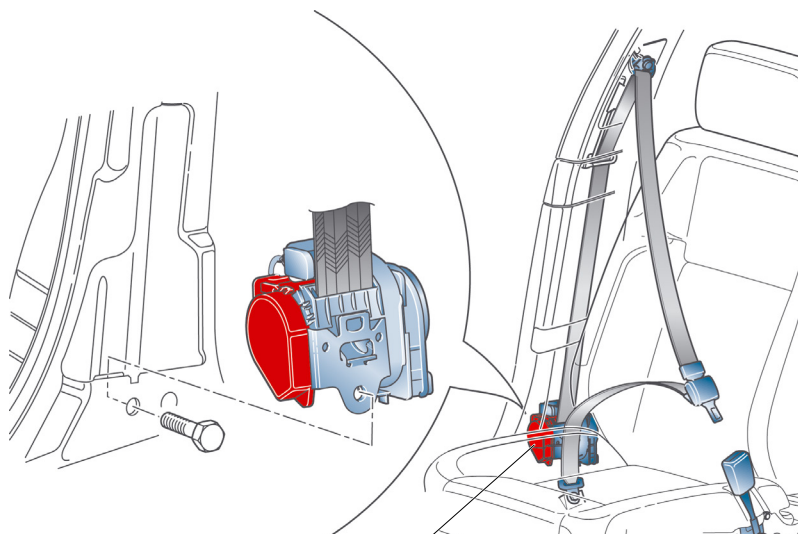

SRB\_061

Ball belt tensioners

Ball belt tensioners are available both with mechanical and electrical tripping. The belt tensioner for the front seat is integrated in the automatic belt retractor.

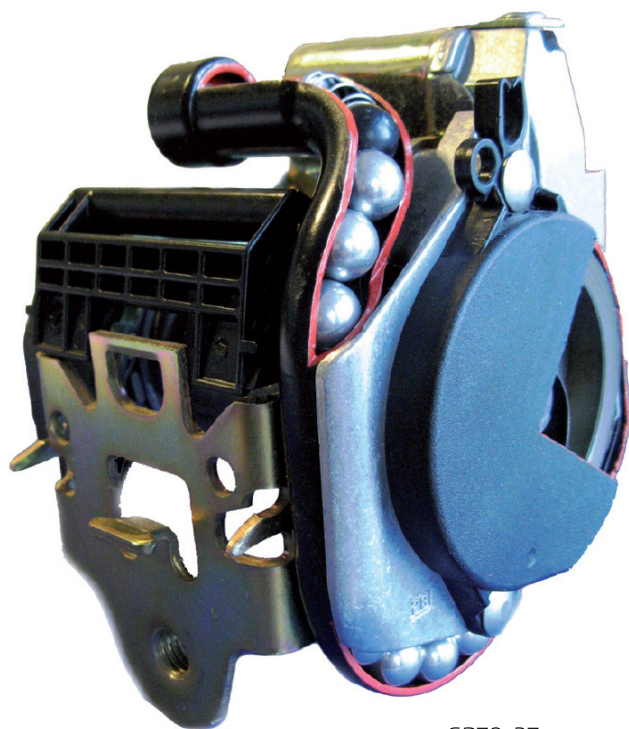

SP78\_37

When triggered, the pyrotechnic propellant is ignited. As a result, the balls are set in motion and start rotating the gear. The gearwheel is fixed to the belt reel, which rolls up the seat belt (tightens). The balls that were driven by the gearwheel are caught in the ball catcher.

## Wankel belt tensioner

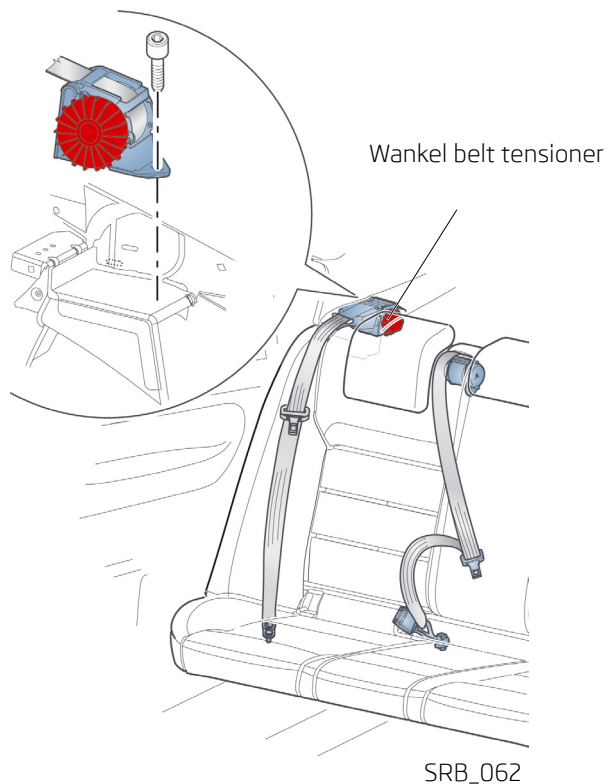

Wankel belt tensioners with rotary pistons are available both with mechanical and electrical tripping. The belt tensioner for the outer rear seats is integrated in the automatic belt retractor.

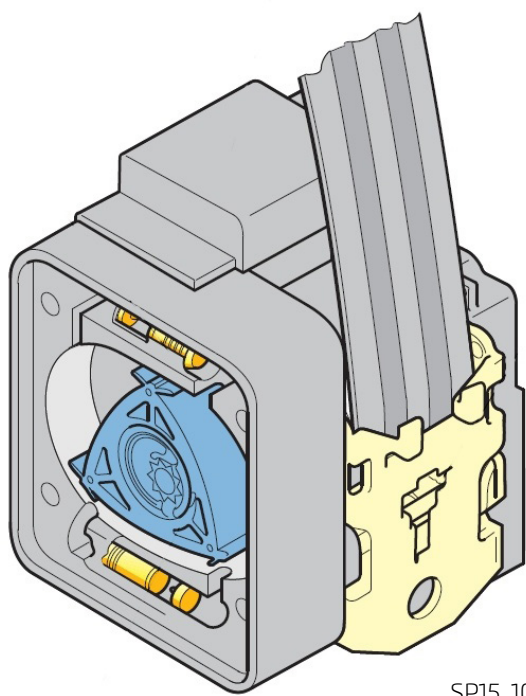

If the propellant charge is ignited, the expanding gases rotate the rotary pistons. Then, the propellant charge is ignited in the second and third chamber. As a result, the piston stops rotating. The rotary piston is connected to the belt reel, which rolls up the seat belt (tightens).



The belt tensioner for the centre rear seat is not currently installed in ŠKODA vehicles.

## Reversible belt tensioners



The reversible belt tensioner PCB forms a shared unit with the pyrotechnic belt tensioners and belt retractor.

The reversible belt tensioner is part of the Pre Crash Base system (PCB), whose task is to stabilise the vehicle occupants in the front seats during critical driving situations. When triggered, the actuator motors for the reversible restraining function that are located in the belt retractor are activated. The seat belt with the reversible restraining function allows 1000 restraining cycles as a result of triggering the PCB system. After this, the entire belt roller module must be replaced.



The reversible belt tensioner does not belong to the pyrotechnic elements, but complements the pyrotechnic belt tensioners.

# Active pedestrian protection

Some ŠKODA Octavia III vehicles are equipped with active front flap hinges in order to increase pedestrian protection.

## Functional description:

The three sensors built in the vehicle's front detect a collision. The actuator pyrotechnics are triggered by the airbag control unit, which is connected to the sensors. The gases flowing from the pyrotechnic cartridges move the actuator piston upward and lift the rear front flap hinges.

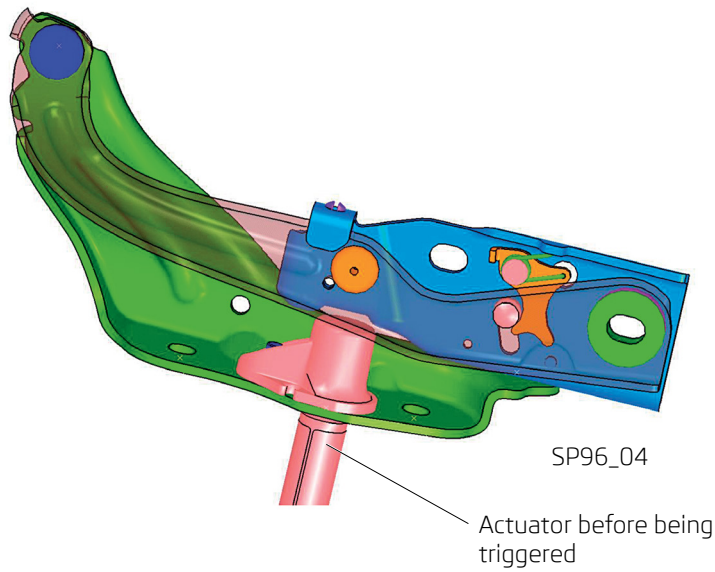

Front flap hinge in starting position

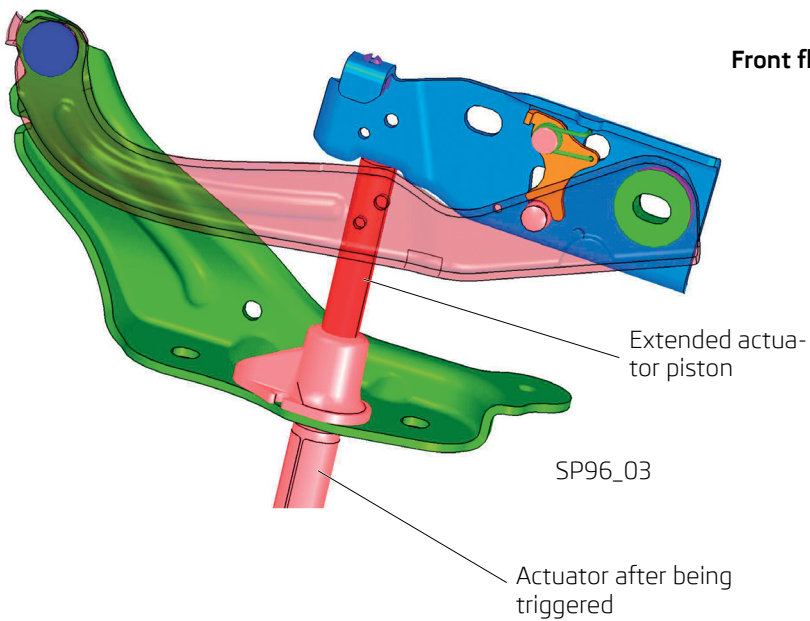

Front flap hinge in actuated position



Crash sensors of the pedestrian protection system

SP96\_12

**Front flap to starting position**



SP96\_11

**Front flap in actuated position**

The front flap is raised by about 55 cm and locked in the triggered position.



# Body of ŠKODA vehicles

## Side impact protection

In ŠKODA vehicles, the side impact protection consists of steel profiles. The profiles are arranged horizontally and diagonally behind the door outer panels and in the sills if necessary.

In the event of a serious accident, the high-strength pipes/profiles can punch through the door panel and hook into the B-pillar (or C-pillar). Then, the door can no longer be opened.

The high-strength profiles can only be separated using modern, powerful hydraulic cutting gear. An angle grinder and other spark-producing tools should not be used if possible.

If a hydraulic special tool is fitted to the door lock, the lock and locking pins are pressed together to form a solid combination, so that the locking pin comes away from the B-pillar. The door cannot yet be released by the wedged impact profile.

It is therefore recommended that the special tool is placed on the door hinges and that they are pushed open individually. In this case, the hinge pin usually tears off and the door can be released and then bent from the front towards the rear.



Caution - the door may jump suddenly.



To illustrate the technical description, the Octavia II was used.

The exact position of the reinforcement measures used in ŠKODA brand vehicles can be found in the rescue datasheets.

The reinforcement measures are illustrated in the rescue datasheets as follows: 

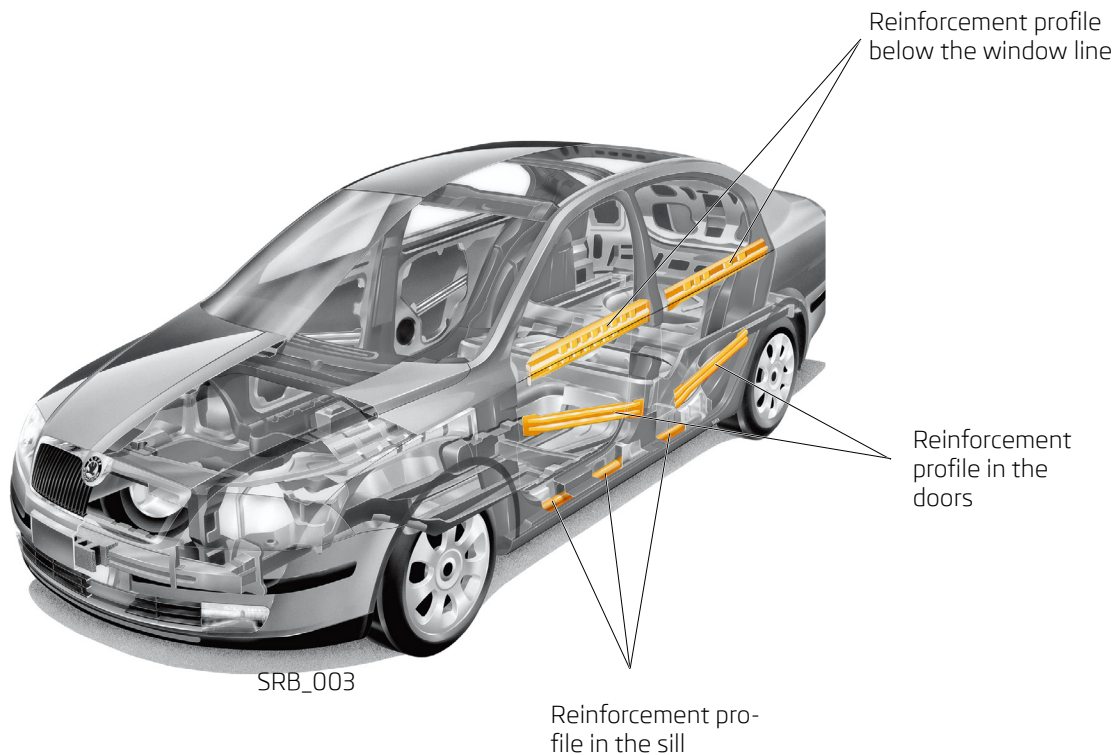

## Body separation areas

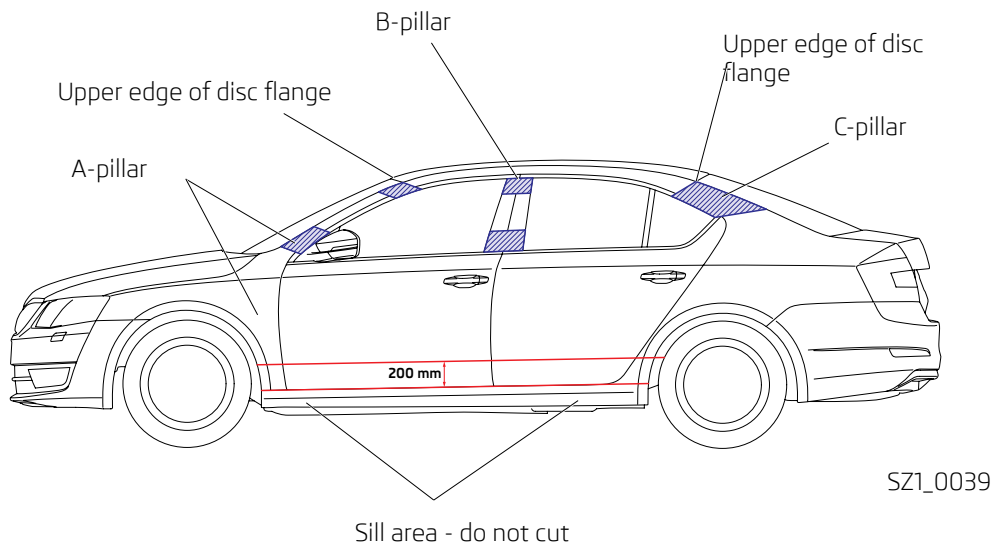

 Only cut in these areas of the pillars.

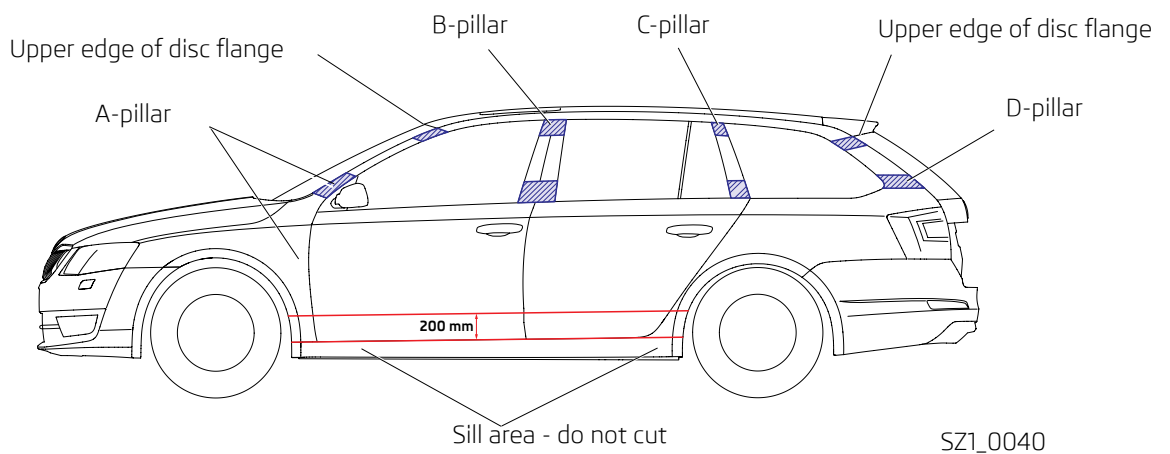

The overview principally shows the separation points for all ŠKODA brand vehicles that permit risk-free cutting in rescue cases (in relation to airbags and belt tensioners) in the hatched areas. Do not cut up to 200 mm above the upper edge of the sill.

## Armoured vehicles

Armoured vehicles can be identified by significantly thicker glass panes. In the event of rescue work, treat these vehicles like normal vehicles. I.e. also rescue people through the doors. It should be noted that cutting and separating work requires more effort and the glass panes cannot be dismantled or destroyed.

## Seven-seater vehicles

Some of ŠKODA's vehicles (currently the Kodiaq) can accommodate up to seven people. These vehicles have a third row of seats.

The third-row seats feature automatic belt retractors without seat belt pre-tensioners.

The extended head-level air bag keeps passengers safe in the event of an accident.

Installed between the A-pillar and the D-pillar, this extended head-level air bag covers the front, rear and third row of seats.



# Body structure of ŠKODA vehicles

The body strength is maintained by using high-strength steels in key areas of the body structure. In this case, the focus is on protecting the passenger compartment as much as possible. In the following pictures, the individual body structures of ŠKODA brand vehicles are illustrated.

## Body structure: Felicia

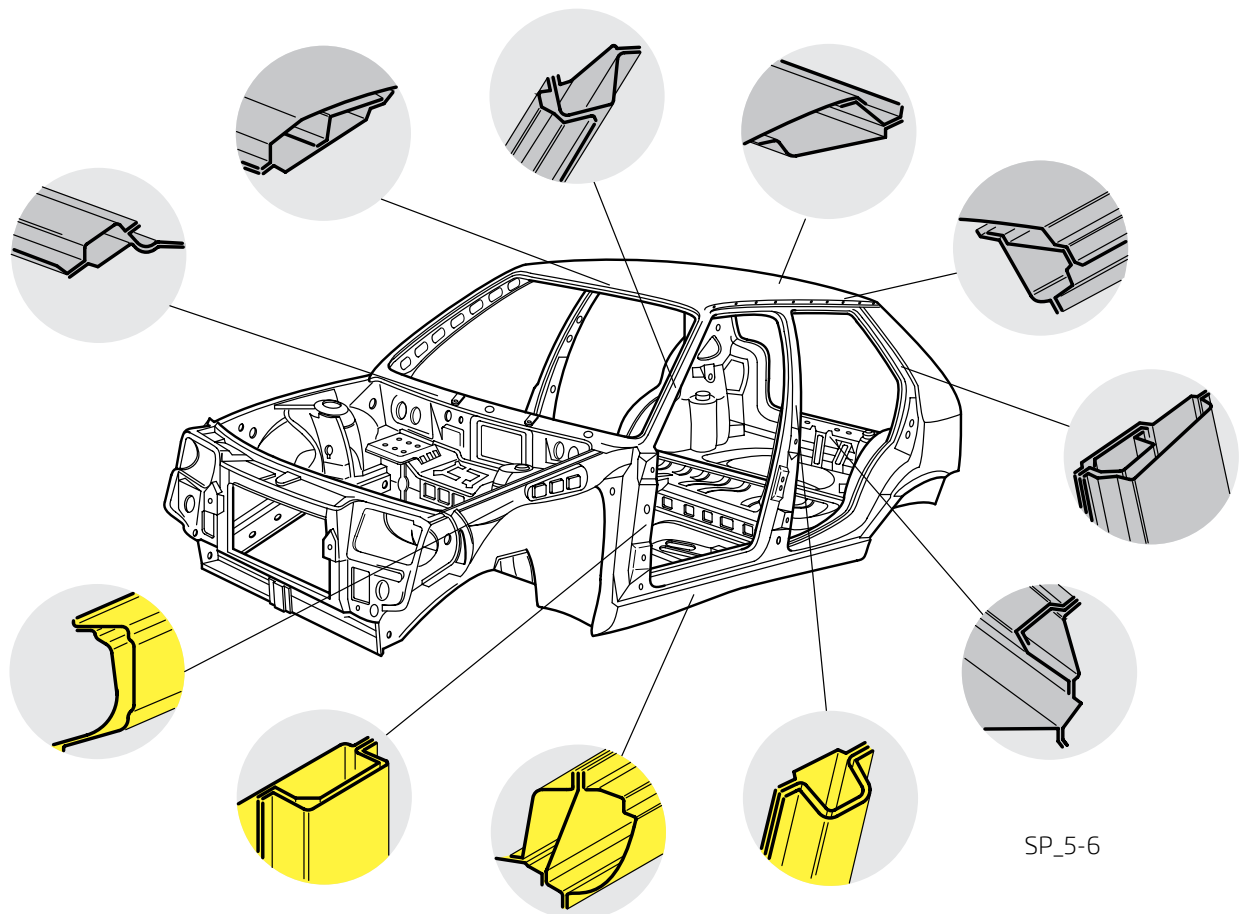

	High strength steels
---	----------------------

## Body structure: Fabia I



SP32\_96

	High strength steels
---	----------------------

## Body structure: Octavia I

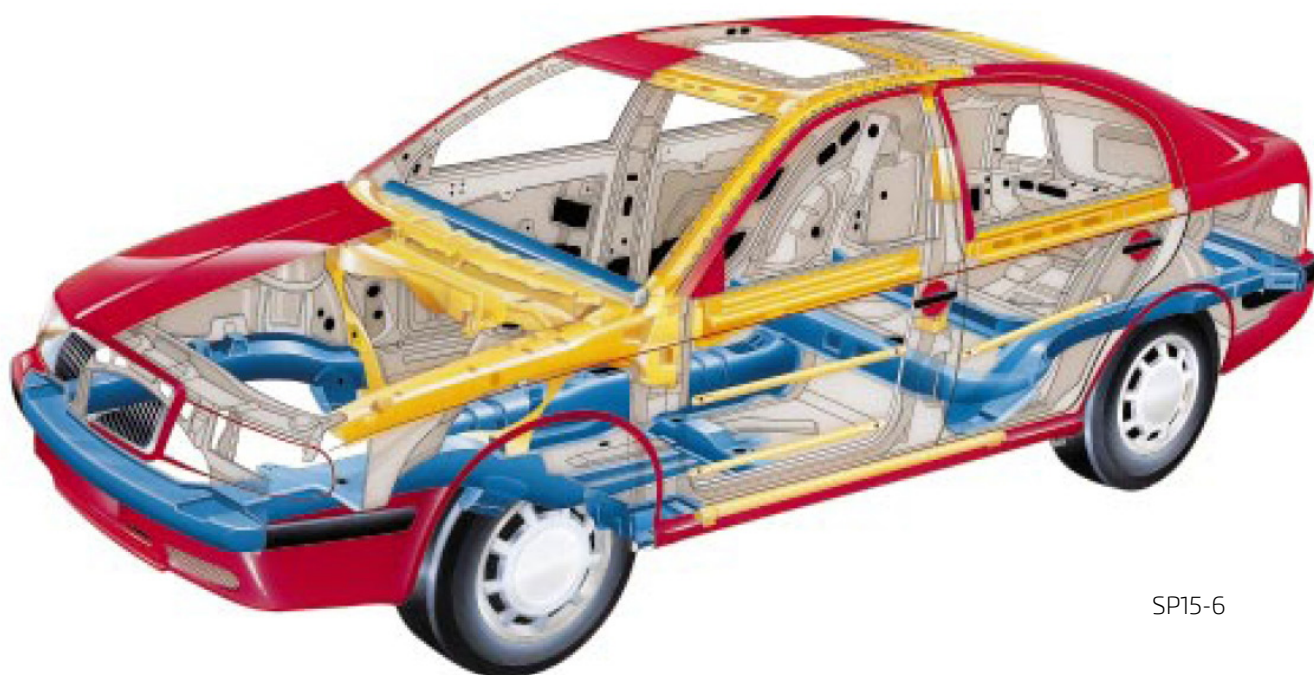

SP15-6

	High strength steels
---	----------------------

## Body structure: Superb I

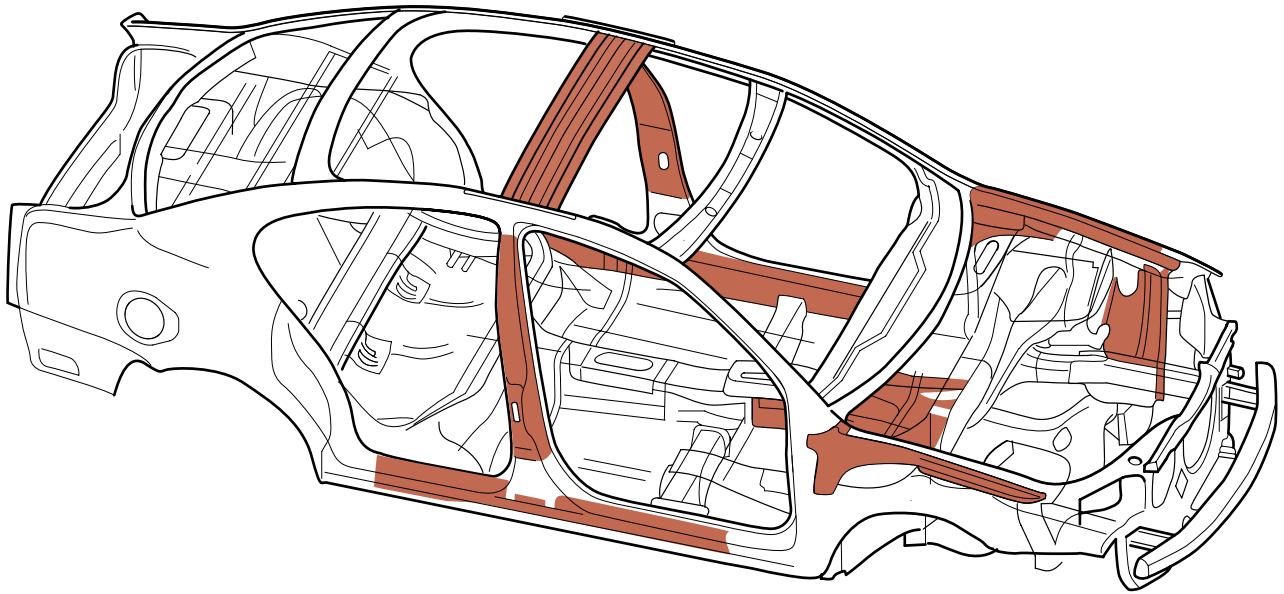

SP47\_32

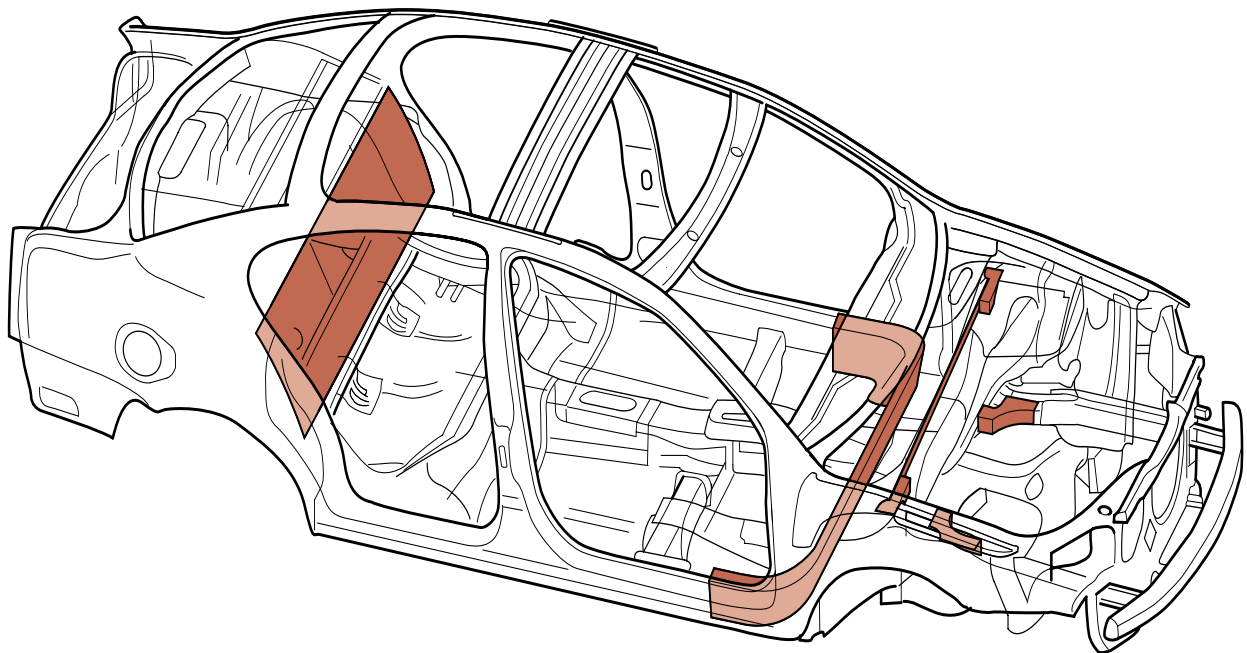





SP47\_33



## Body structure: Octavia II

A combination of certain types of sheet metals form the car body structure. By using solid sheets, the strength of the individual components could be increased, but not at the expense of body weight.

The steel is divided into several groups according to the flow limit.

	< 220 MPa
	220 - 300 MPa
	300 - 550 MPa
	> 550 MPa

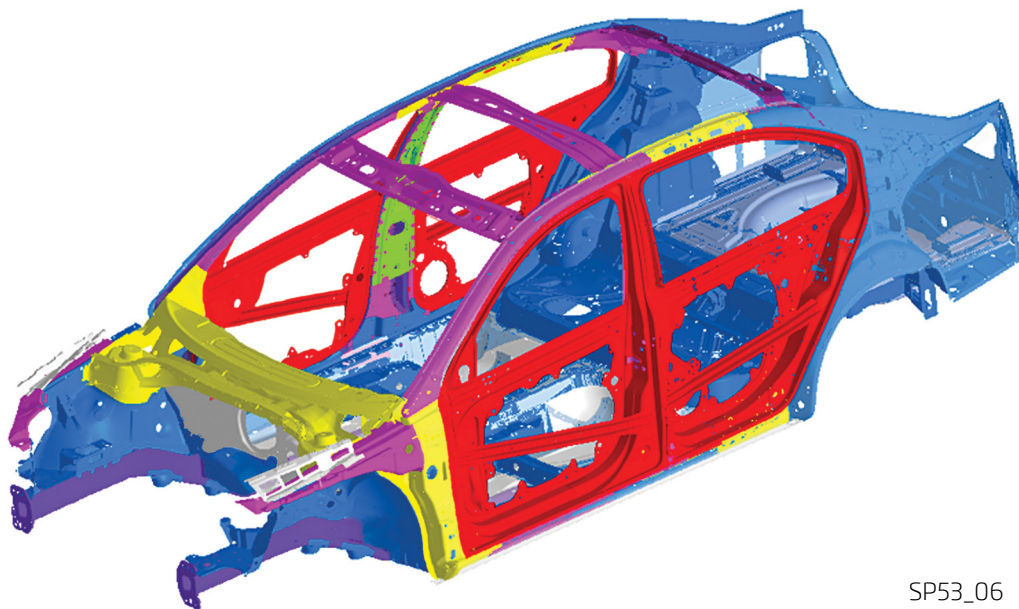





SP53\_06



## Body structure: Fabia II

A combination of certain types of sheet metals form the car body structure. By using solid sheets, the strength of the individual components could be increased, but not at the expense of body weight.

The steel is divided into several groups according to the flow limit.

	< 180 MPa
	180 - 300 MPa
	300 - 500 MPa
	> 550 MPa

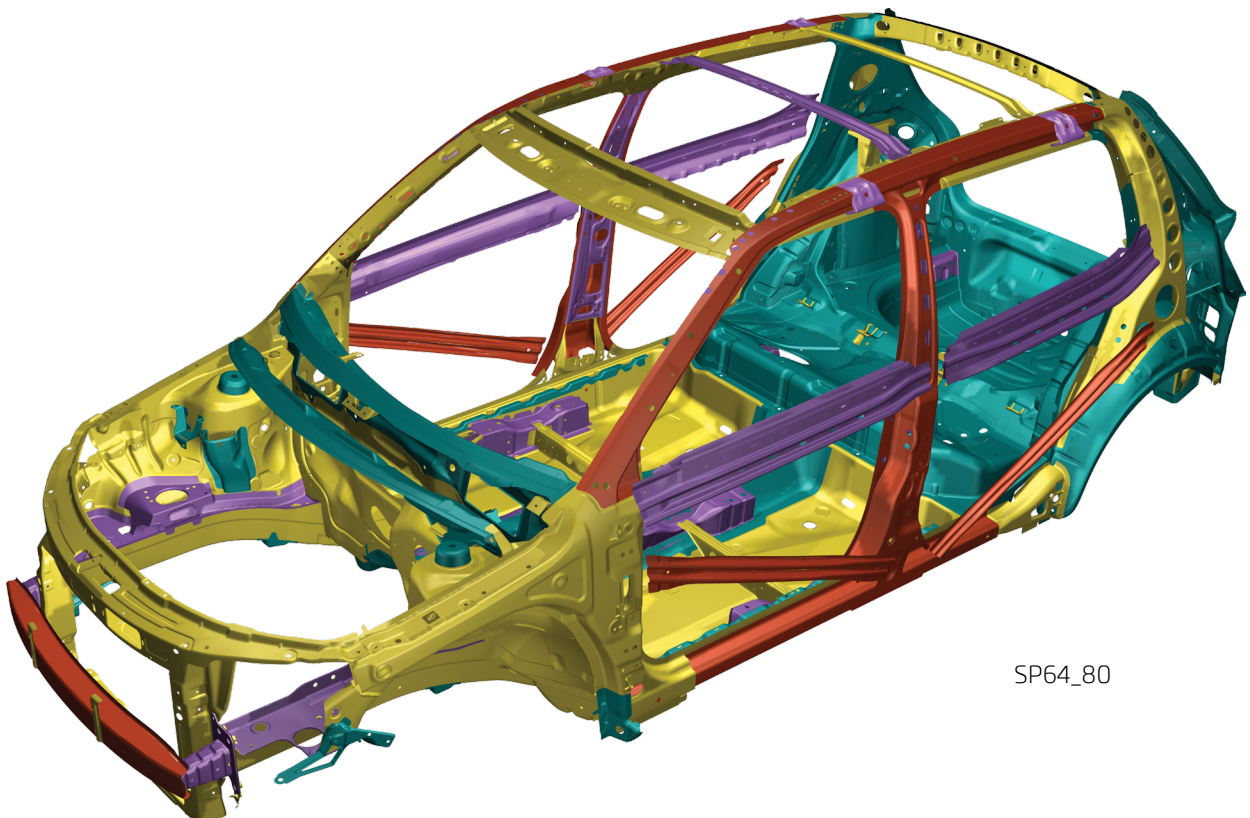





SP64\_80



## Body structure: Roomster

A combination of certain types of sheet metals form the car body structure. By using solid sheets, the strength of the individual components could be increased, but not at the expense of body weight.

The steel is divided into several groups according to the flow limit.

	< 180 MPa
	180 - 300 MPa
	300 - 500 MPa
	> 550 MPa

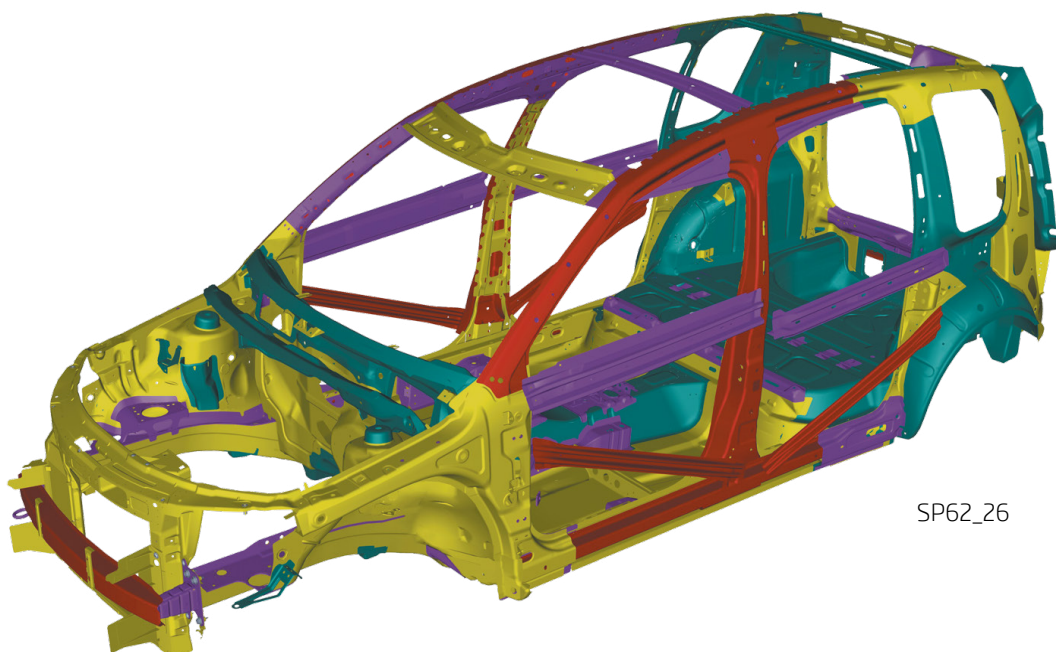





SP62\_26

## Body structure: Superb II

A combination of certain types of sheet metals form the car body structure. By using solid sheets, the strength of the individual components could be increased, but not at the expense of body weight.

The steel is divided into several groups according to the flow limit.



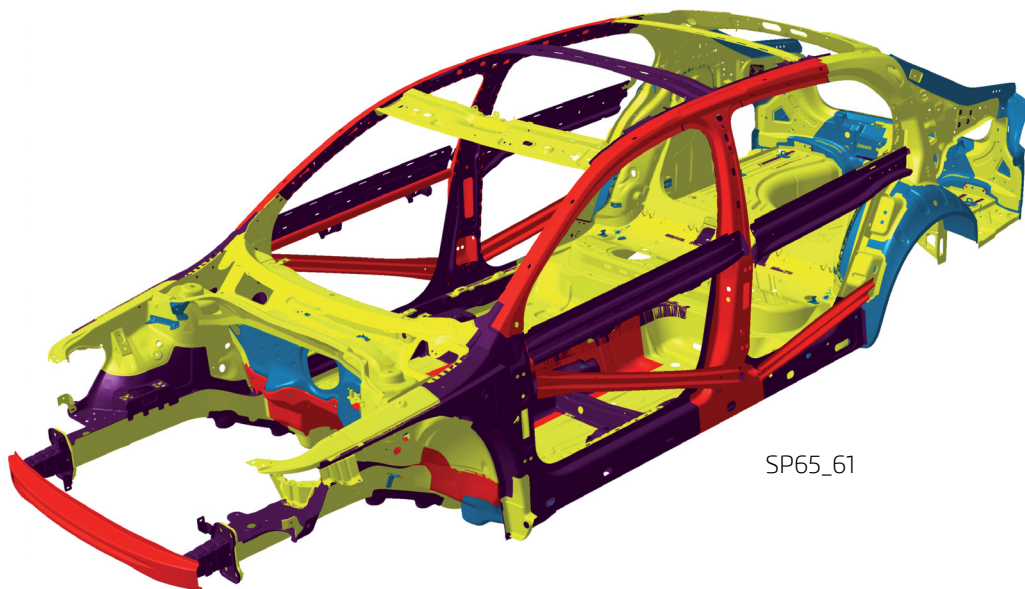

	< 180 MPa
	180 - 300 MPa
	300 - 500 MPa
	> 500 MPa



## Body structure: Yeti

A combination of certain types of sheet metals form the car body structure. By using solid sheets, the strength of the individual components could be increased, but not at the expense of body weight.

The steel is divided into several groups according to the flow limit.

	< 180 MPa
	190 - 260 MPa
	300 - 500 MPa
	> 500 MPa

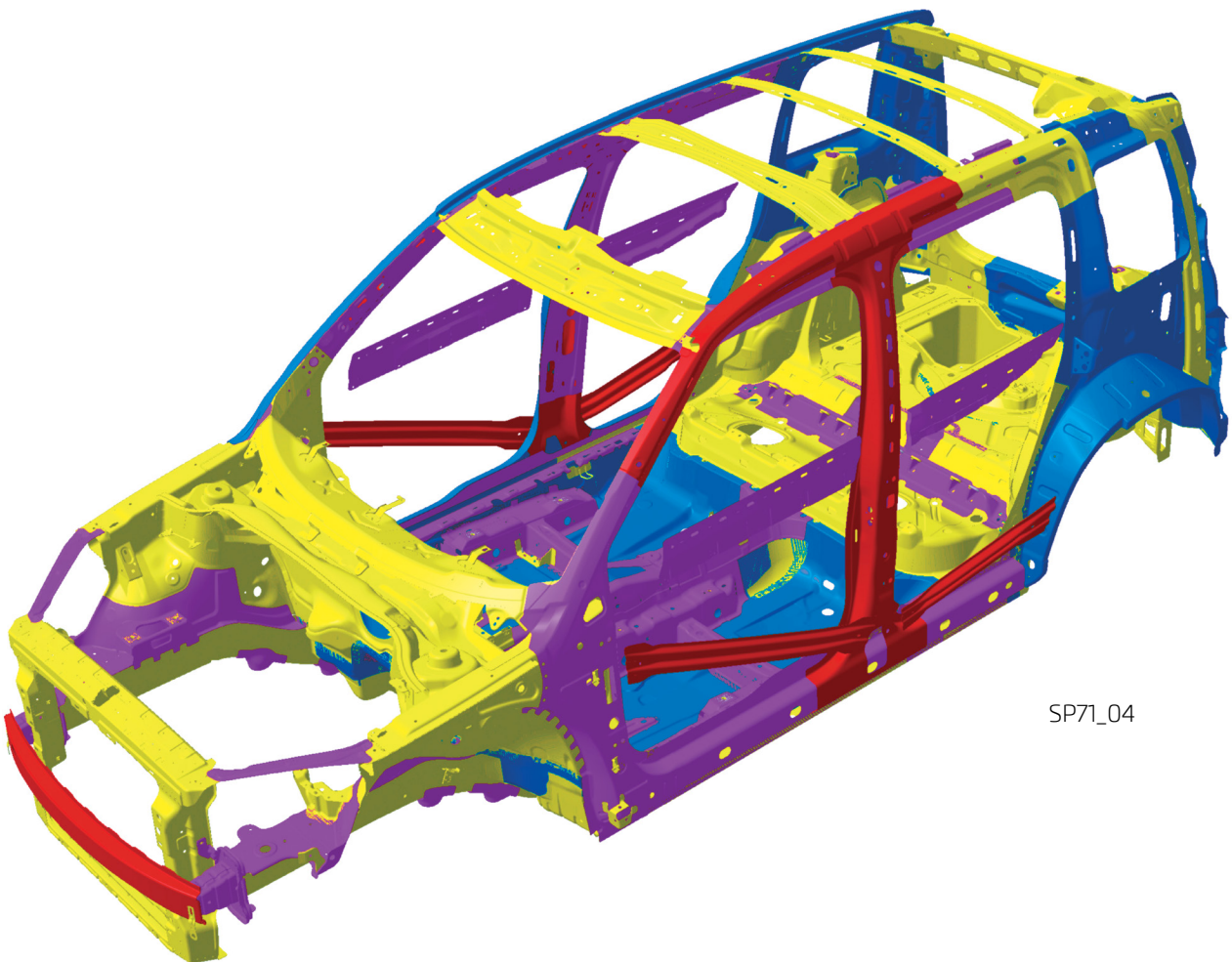





SP71\_04

## Body structure: Citigo

A combination of certain types of sheet metals form the car body structure. By using solid sheets, the strength of the individual components could be increased, but not at the expense of body weight. The proportion of high-strength steels is very high.

The steels are divided into the following groups in respect of resistance.

	< 350 MPa
	300 - 590 MPa
	300 - 590 MPa
	500 - 980 MPa
	> 1400 MPa

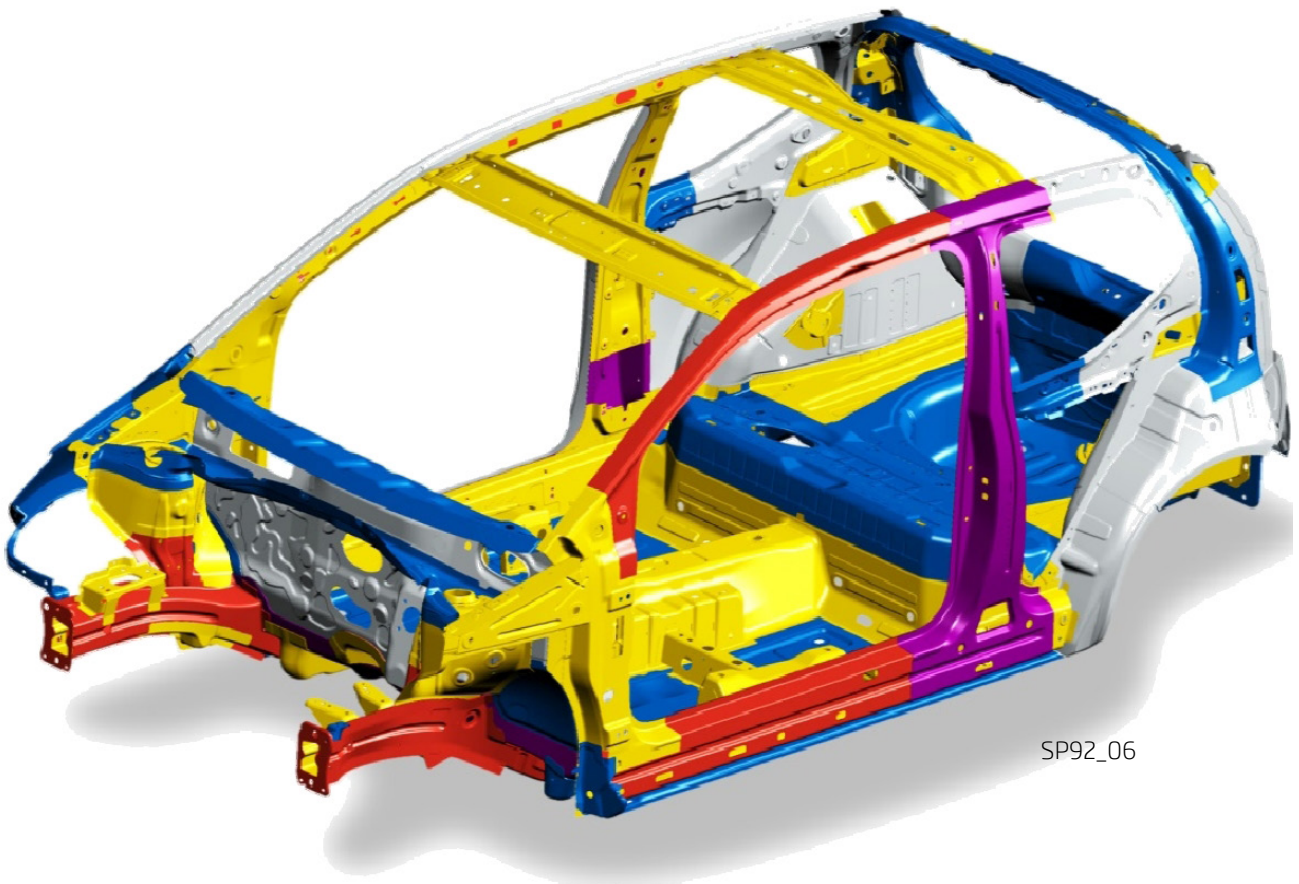





SP92\_06

## Body structure: Rapid

A combination of certain types of sheet metals form the car body structure. By using solid sheets, the strength of the individual components could be increased, but not at the expense of body weight.

The steel is divided into several groups according to the flow limit.

	< 200 MPa
	220 - 420 MPa
	700 - 850 MPa
	1000 - 1200 MPa

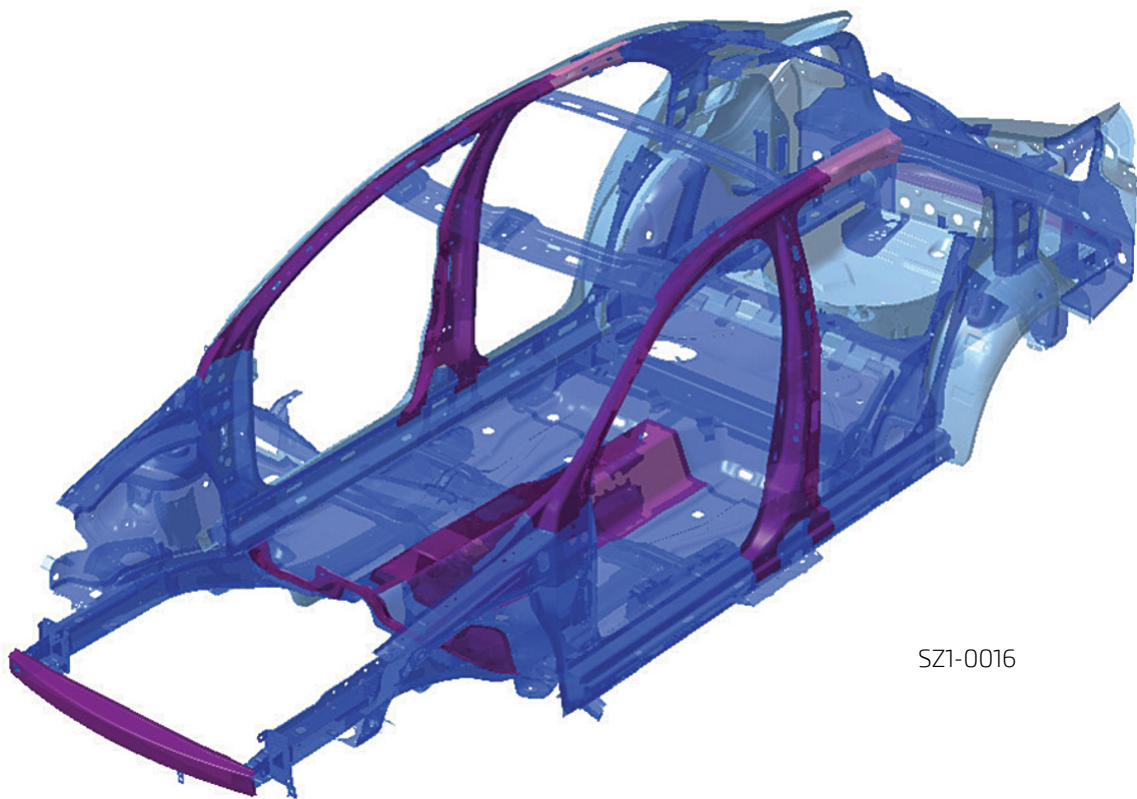





SZ1-0016



## Body structure: Octavia III

A combination of certain types of sheet metals form the car body structure. By using solid sheets, the strength of the individual components could be increased, but not at the expense of body weight.

The steel is divided into several groups according to the flow limit.

	< 200 MPa
	220 - 420 MPa
	700 - 850 MPa
	1000 - 1200 MPa

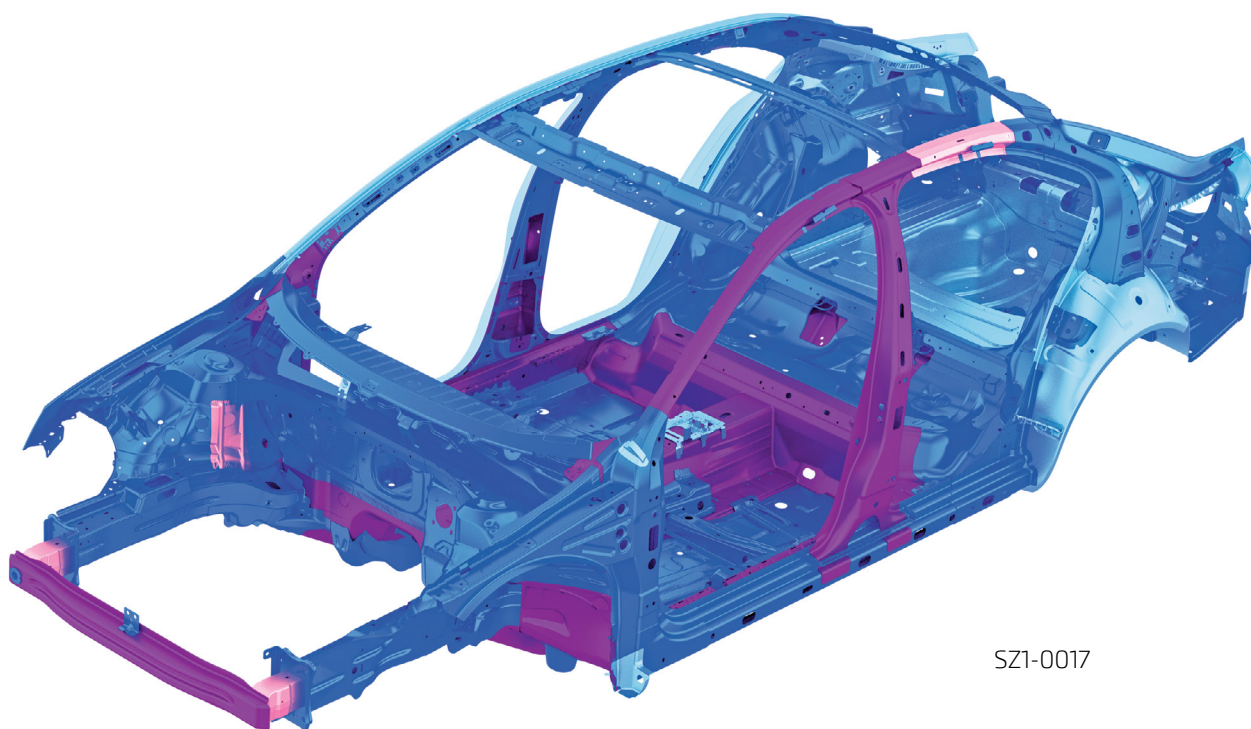





SZ1-0017



## Body structure of Fabia III

A combination of certain types of sheet metals form the car body structure. By using solid sheets, the strength of the individual components could be increased, but not at the expense of body weight.

The steel is divided into several groups according to the flow limit.



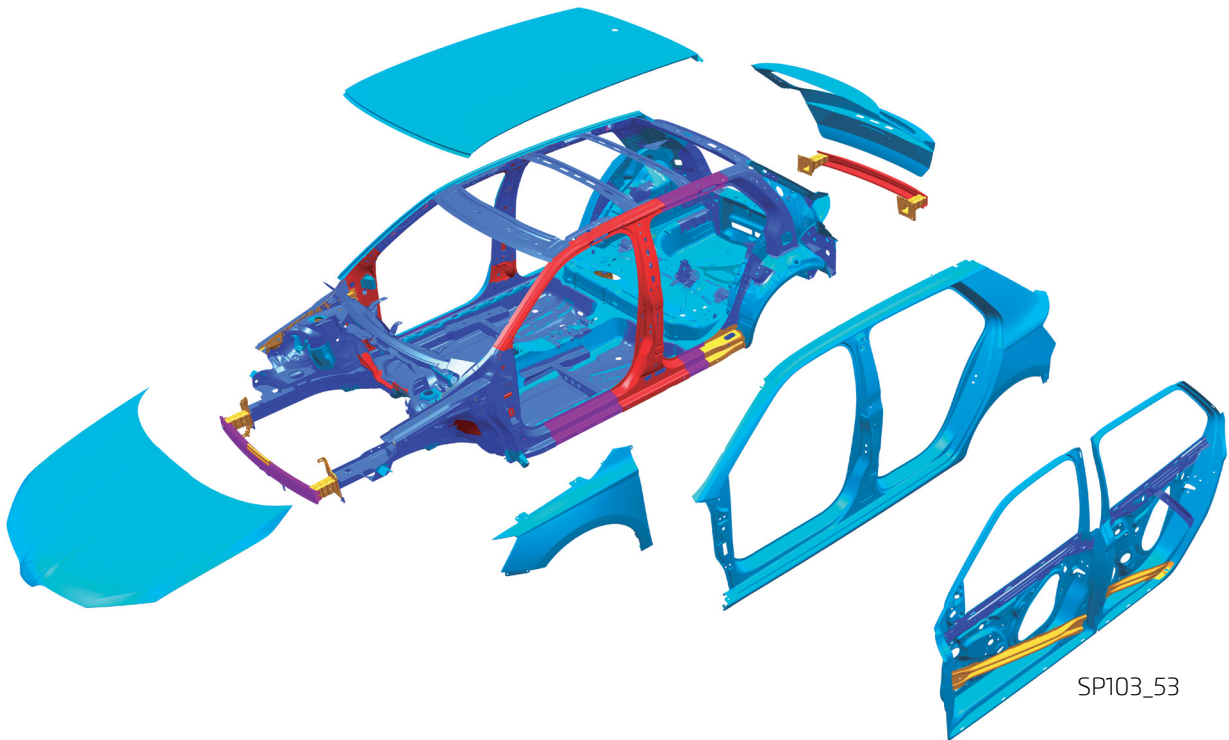

	< 200 MPa
	200 - 400 MPa
	400 - 700 MPa
	700 - 1000 MPa
	1000 - 1200 MPa



## Body structure of Superb III

A combination of certain types of sheet metals form the car body structure. By using solid sheets, the strength of the individual components could be increased, but not at the expense of body weight.

The steel is divided into several groups according to the flow limit.

	< 200 MPa
	200 - 400 MPa
	400 - 700 MPa
	700 - 1000 MPa
	1000 - 1200 MPa

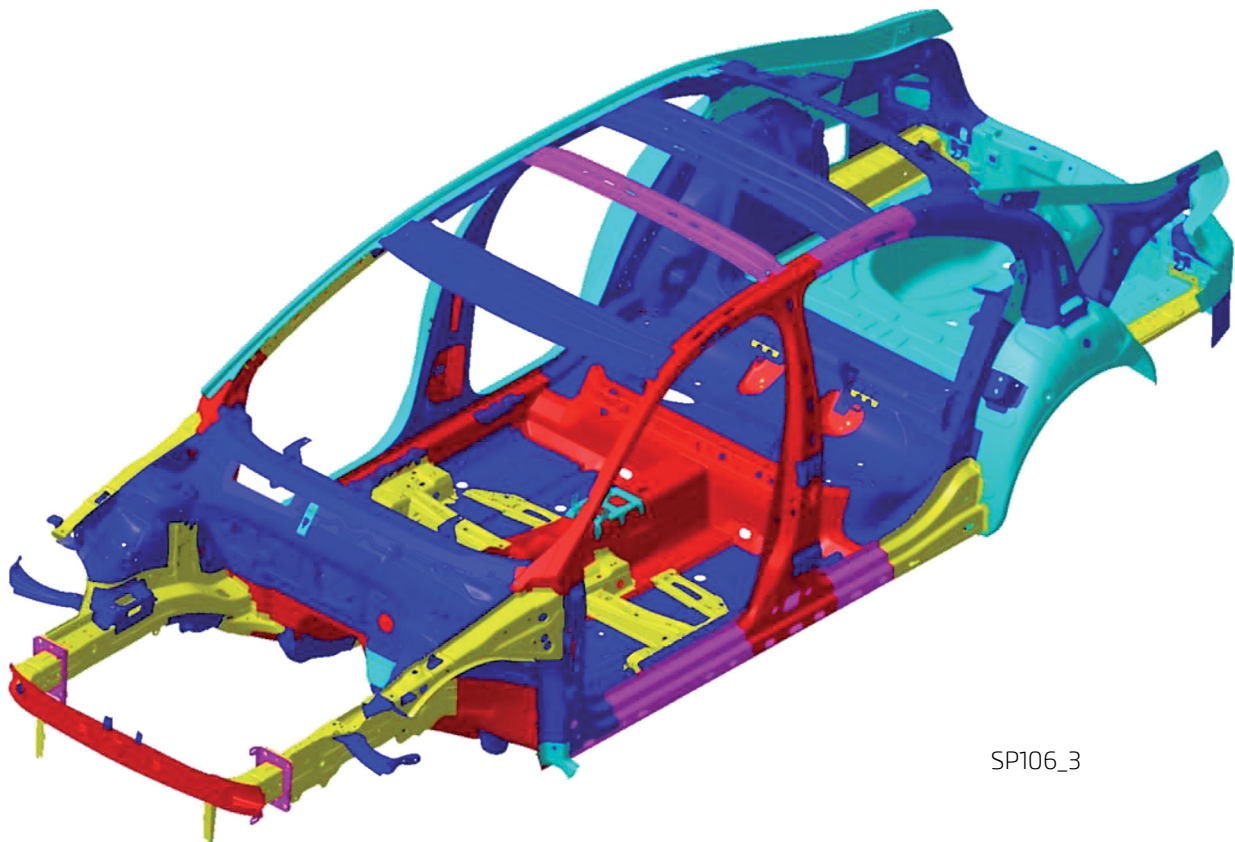





SP106\_3

## Body structure of Kodiah

A combination of certain types of sheet metals form the car body structure. By using solid sheets, the strength of the individual components could be increased, but not at the expense of body weight.

The steel is divided into several groups according to the flow limit.

	< 200 MPa
	200 - 400 MPa
	400 - 700 MPa
	700 - 1000 MPa
	1000 - 1200 MPa

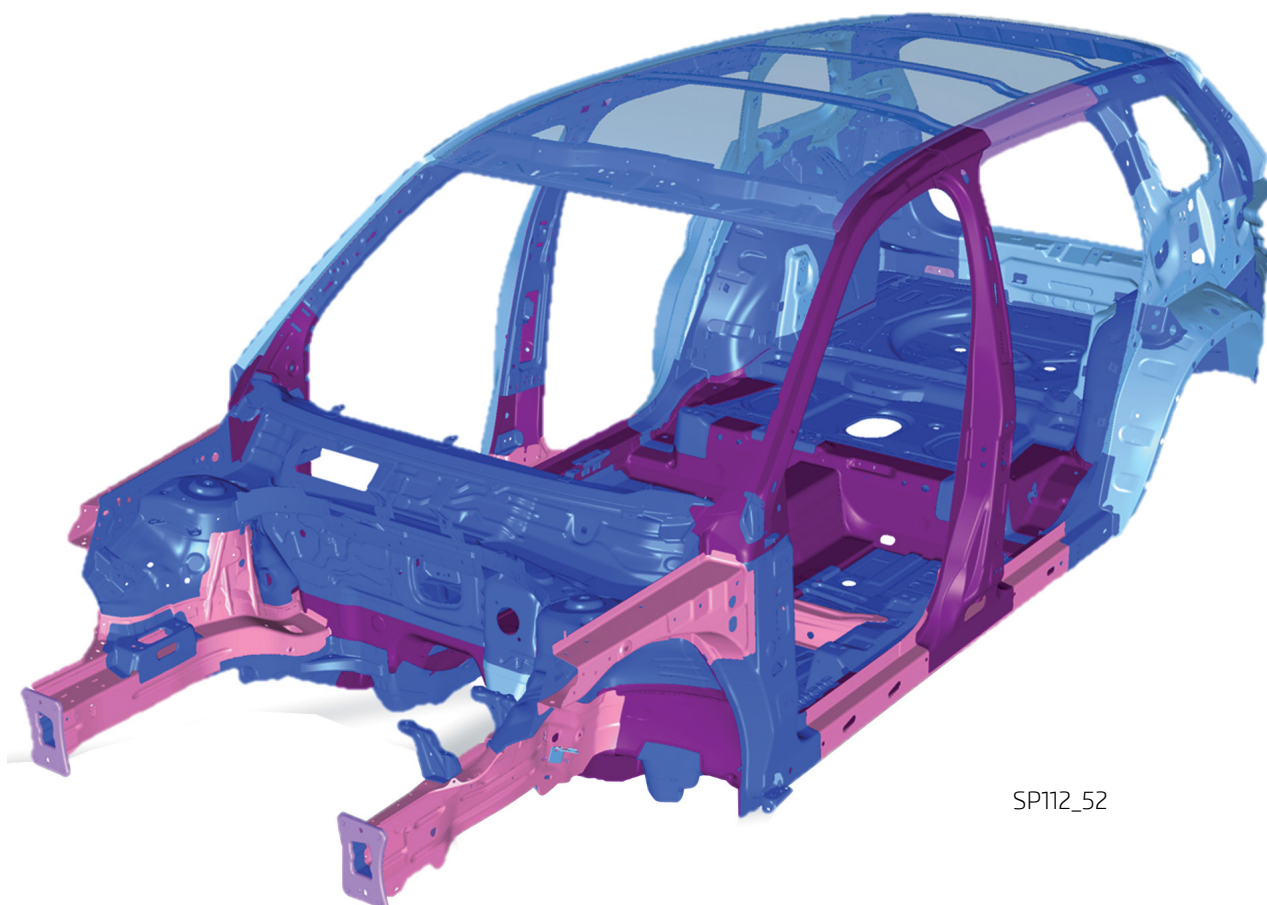





SP112\_52

# Body structure of Karoq

A combination of certain types of sheet metals form the car body structure. By using solid sheets, the strength of the individual components could be increased, but not at the expense of body weight.

The steel is divided into several groups according to the flow limit.

	< 200 MPa
	200 - 400 MPa
	400 - 700 MPa
	700 - 1000 MPa
	1000 - 1200 MPa

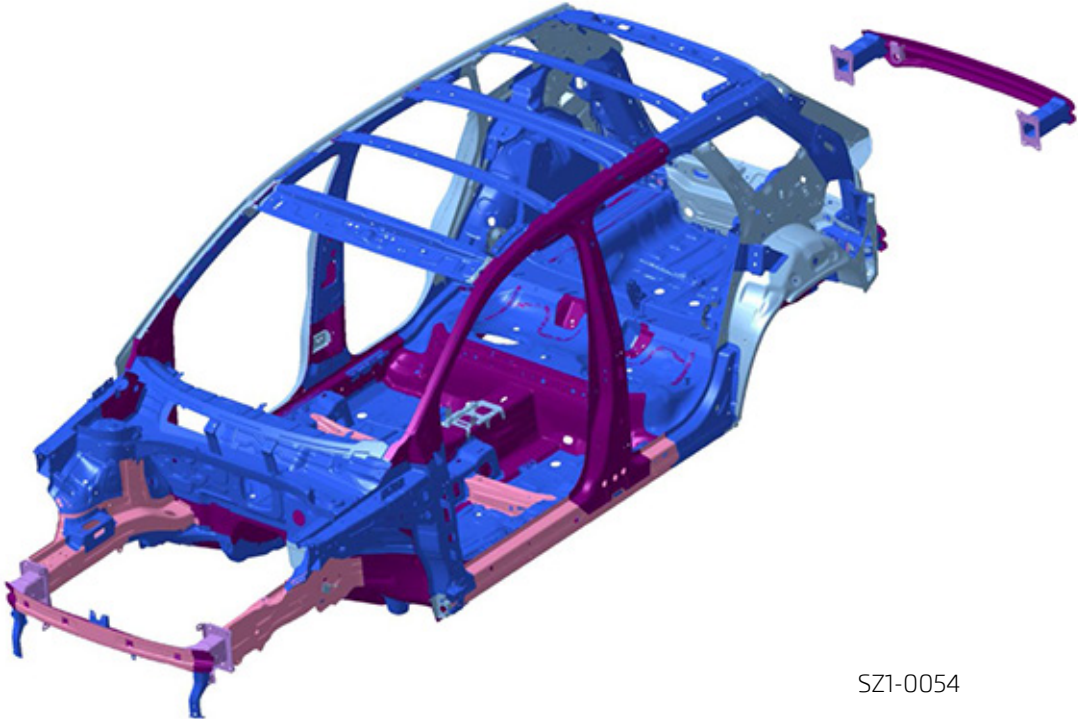





SZ1-0054

# Body structure of Scala

A combination of certain types of sheet metals form the car body structure. By using solid sheets, the strength of the individual components could be increased, but not at the expense of body weight.

The steel is divided into several groups according to the flow limit.

	< 200 MPa
	200 - 420 MPa
	400 - 700 MPa
	600 - 1000 MPa
	1000 - 1200 MPa

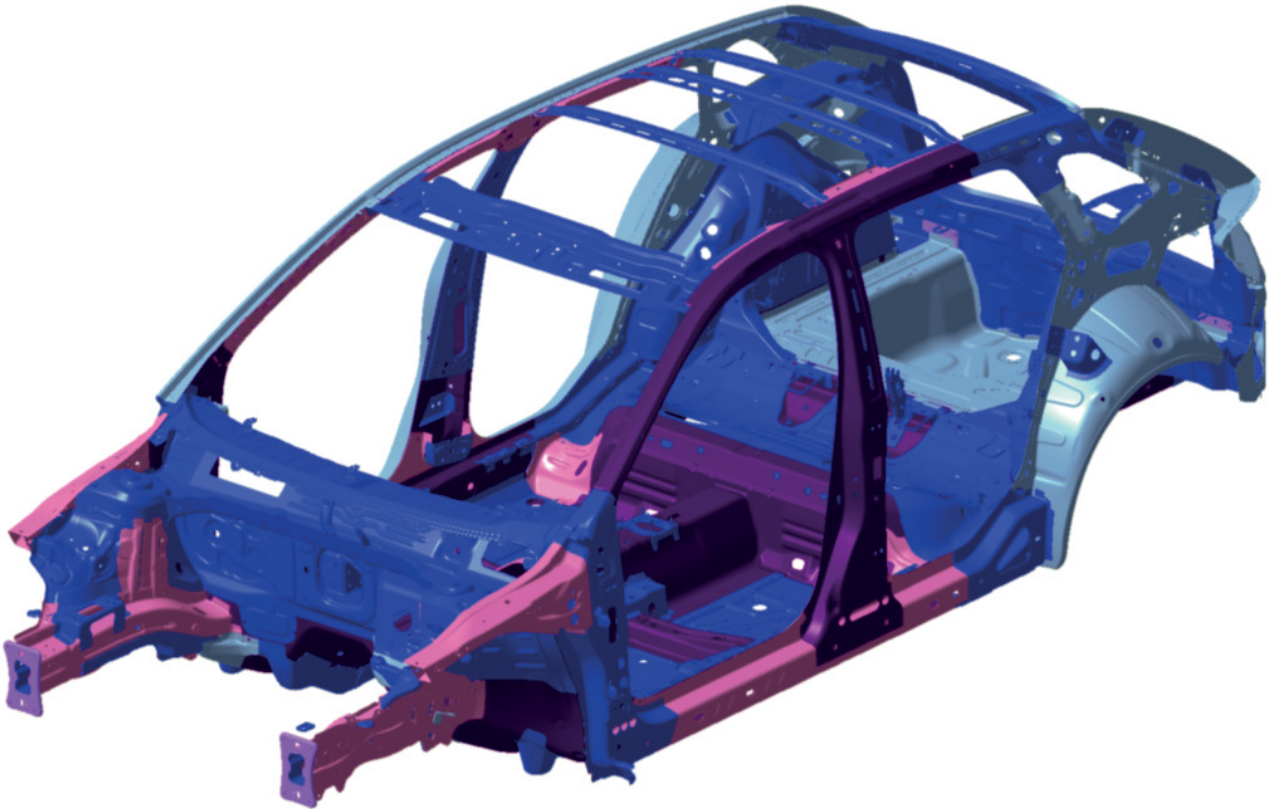





SZ1-0055



# Body structure of Kamiq

A combination of certain types of sheet metals form the car body structure. By using solid sheets, the strength of the individual components could be increased, but not at the expense of body weight.

The steel is divided into several groups according to the flow limit.

	< 200 MPa
	200 - 420 MPa
	400 - 700 MPa
	600 - 1000 MPa
	1000 - 1200 MPa

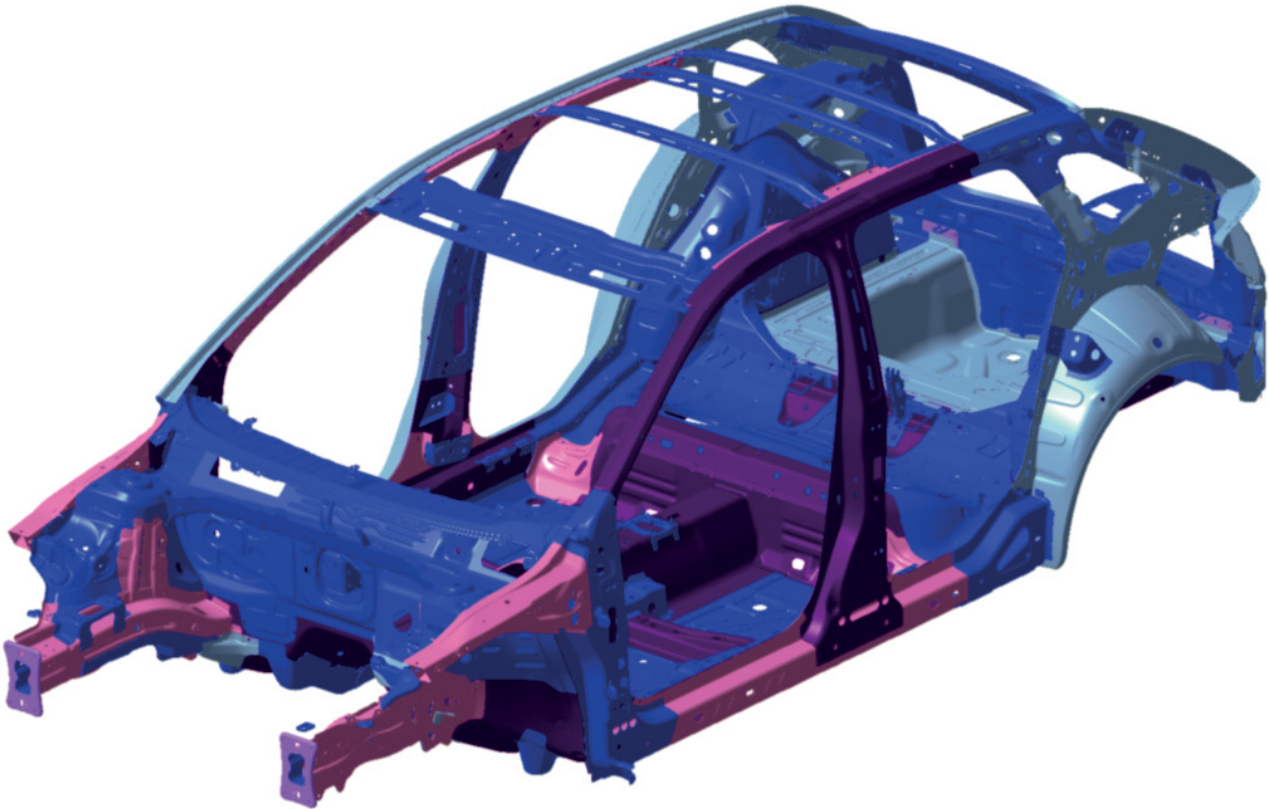





SZ1-0055



## Body structure of Octavia IV

A combination of certain types of sheet metals form the car body structure. By using solid sheets, the strength of the individual components could be increased, but not at the expense of body weight.

The steel is divided into several groups according to the flow limit.

	< 200 MPa
	220 - 420 MPa
	700 - 850 MPa
	> 1200 MPa







SZ1-0056

## Body structure of Citigo-e iV

A combination of certain types of sheet metals form the car body structure. By using solid sheets, the strength of the individual components could be increased, but not at the expense of body weight.

The steel is divided into several groups according to the flow limit.

	< 350 MPa
	300 - 590 MPa
	300 - 590 MPa
	500 - 980 MPa
	> 1400 MPa

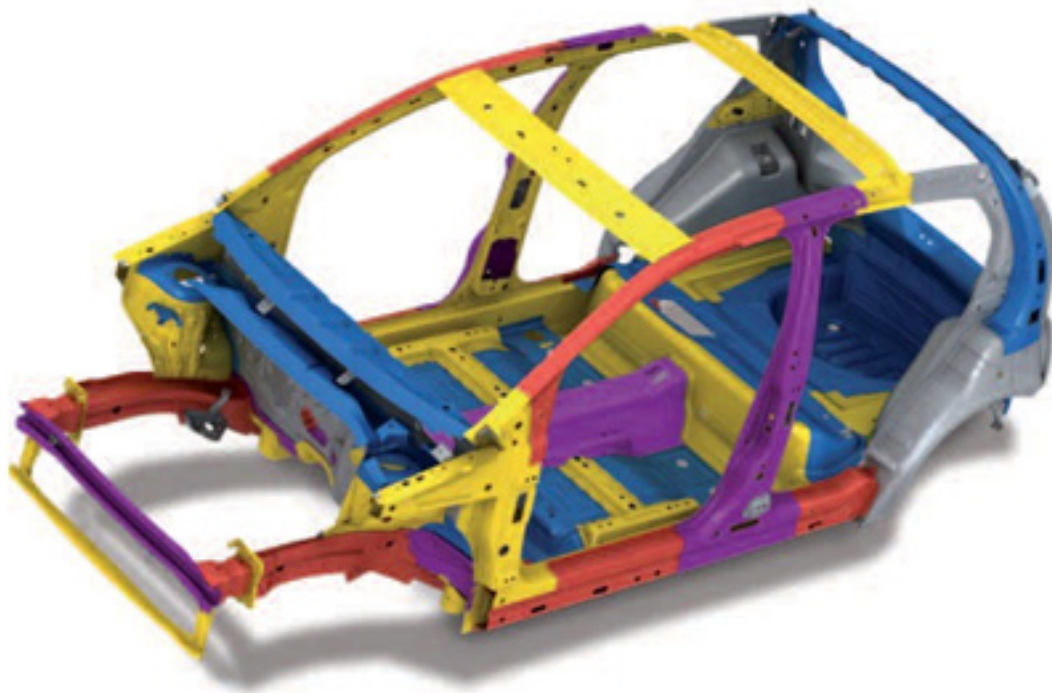

SZ1-0057

# Vehicle glazing

ŠKODA vehicles are equipped with two different types of glazing:

- > Tempered safety glass **TSG**.
- > Laminated safety glass **LSG**.

## Tempered safety glass (TSG)

Is used for the vehicle side windows, rear windscreen and sunroofs. It consists of thermally pre-treated glass that can withstand high loads. If the load is too high, the glass shatters into many crumbs that are not particularly sharp.

## Laminated safety glass (LSG)

Is used in the vehicle windscreen and optionally in the side windows. It consists of two glass panes that are held together by a film. Therefore, the panes remain largely intact if they are damaged. The front windows are made from LSG on all vehicles and are bonded to the body. Side windows and sunroofs can either move, designed to hinge or are also bonded.

To remove laminated safety glass, special glass or plate saws shredders are particularly suitable. Tempered safety glass can be removed by point loading, for example, with a spring centre punch or an emergency hammer. The panes should be protected accordingly beforehand.



Before removing glass panes, the passenger must always be protected from dust and splinters!



It is possible that intact TSG panes shatter abruptly when using rescue equipment. Therefore, TSG panes must be removed depending on the situation and extent of rescue work. As laminated safety glass does not shatter suddenly, panes like these should only be removed for operational reasons.

# Alternative fuel vehicles

## Natural gas vehicles

Vehicles powered by natural gas are different in some respects from conventional vehicles or vehicles powered by LPG. When carrying out a rescue operation involving vehicles, it is very important to know these differences.

The ŠKODA factory manufactures some models powered by natural gas.

All ŠKODA natural-gas-powered vehicles can either run on natural gas or petrol.

In the case of natural gas-powered vehicles, the drive is primarily powered by natural gas. The engine cannot be switched to petrol mode by the user.

Handling of natural gas vehicles is as safe as handling petrol or diesel vehicles. However, for storage, operation and repair purposes, additional safety regulations apply, e.g. the **Standard TPG 982 02**.

## ŠKODA natural-gas-powered Citigo vehicle

The ŠKODA Citigo gas-powered vehicle has a reserve petrol tank with a capacity of approx. 10 liters.

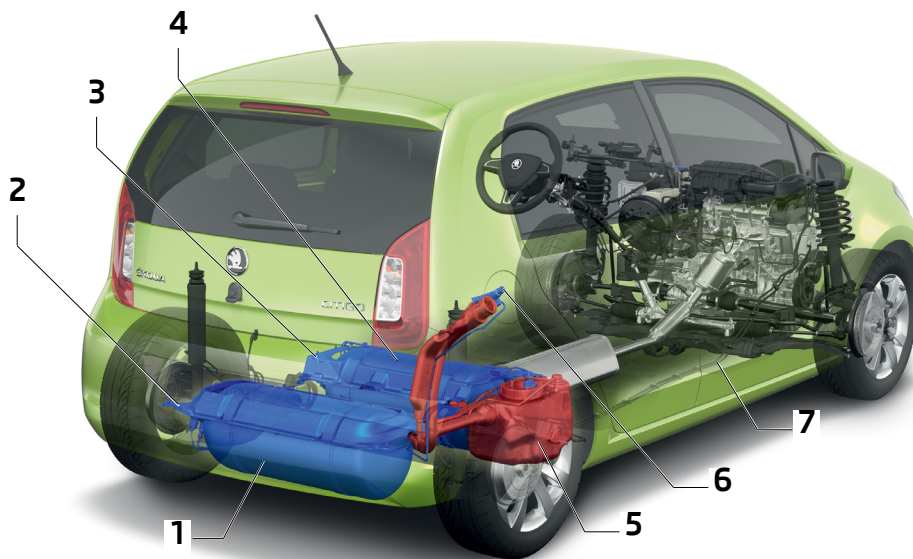

SP102\_32

1. Gas tank behind the rear axle
2. Multifunction valve for the gas tank behind the rear axle
3. Multifunction valve of the gas tank in front of the rear axle
4. Gas tank in front of the rear axle
5. Petrol fuel tank
6. Filler pipe
7. High-pressure gas line

## Natural gas powered vehicle ŠKODA Octavia III

The natural gas-powered ŠKODA Octavia III has a fully-fledged petrol tank with a capacity of approx. 50 liters.

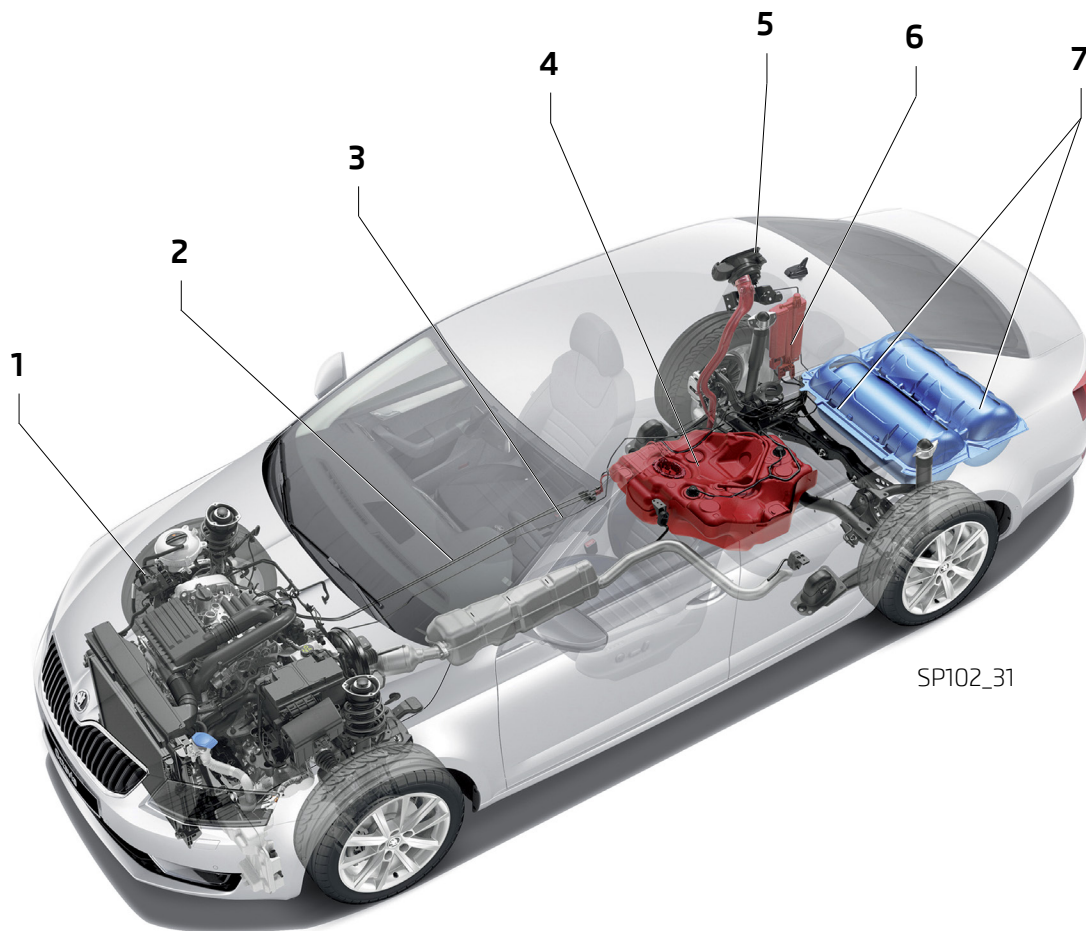

1. Gas pressure regulator
2. Fuel line
3. High-pressure gas line
4. Petrol fuel tank
5. Filler pipe
6. Activated carbon canister
7. natural gas tanks

## ŠKODA Octavia III Facelift natural gas vehicle (from 01/2019 onwards)

The ŠKODA Octavia III Facelift natural gas vehicle has a reserve petrol tank with a capacity of approx. 10.5 litres.

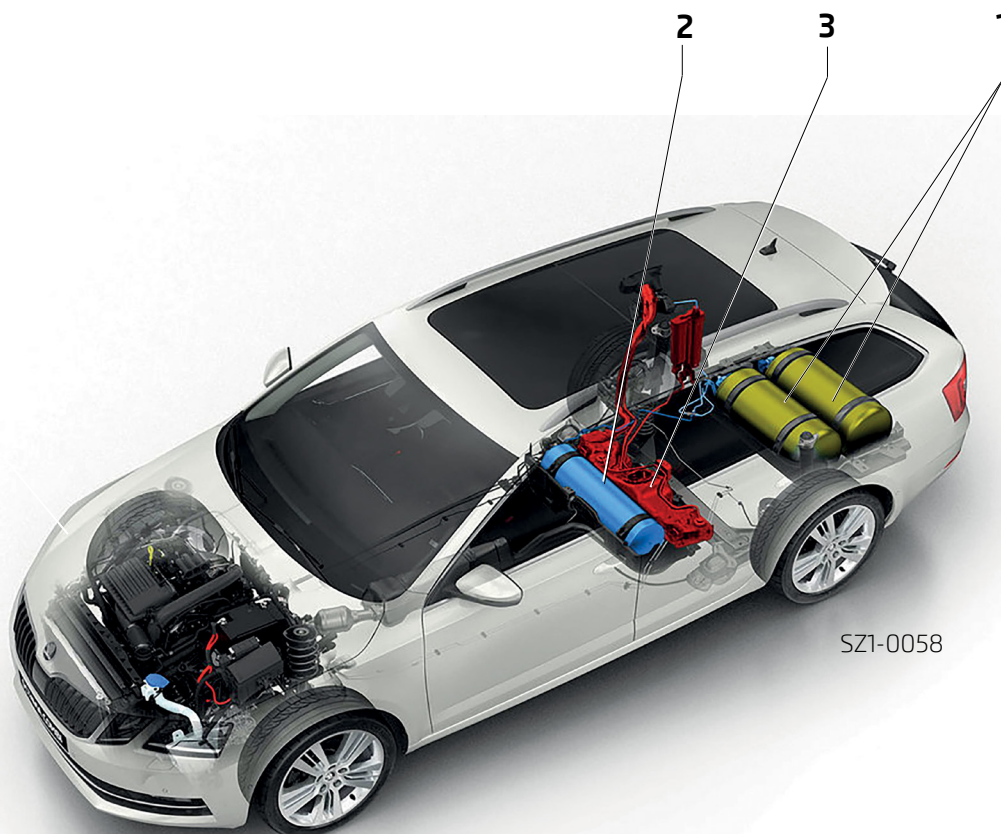

1. CFRP natural gas tank
2. Steel natural gas tank
3. 10.5 l petrol tank



## ŠKODA SCALA and KAMIQ natural gas vehicles

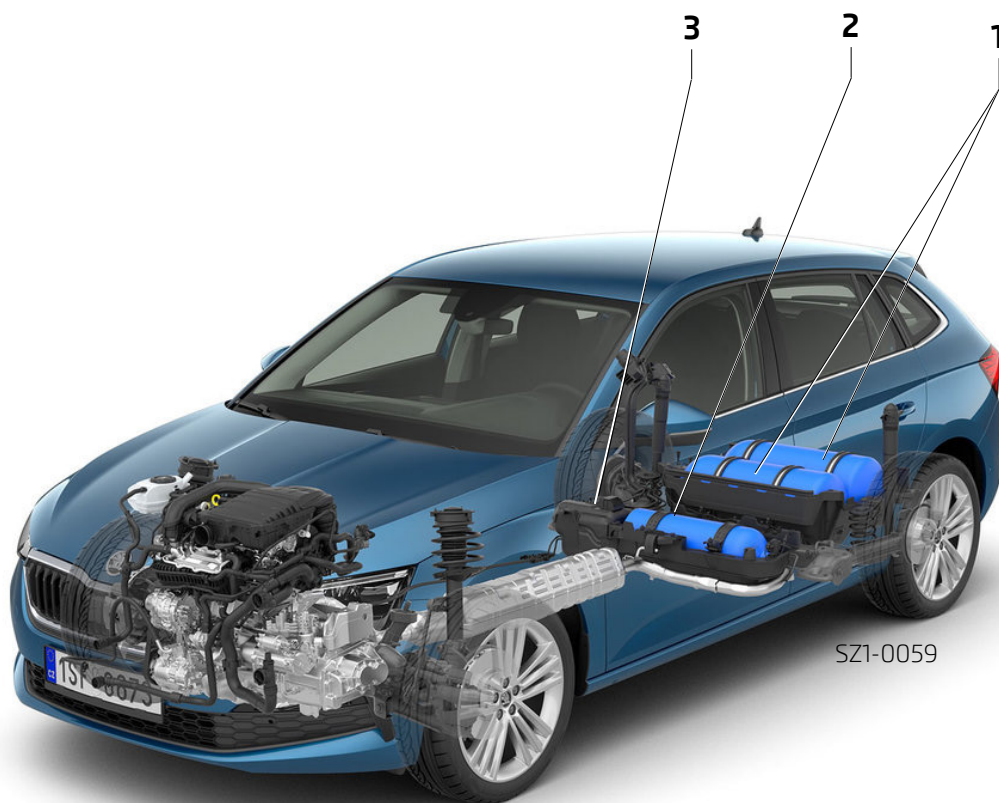

1. Steel natural gas tank
2. Steel natural gas tank
3. 9 l petrol tank



Natural gas (also known as CNG – compressed natural gas) must not be confused with liquefied petroleum gas (also known as LPG). LPG and CNG systems have different fundamental properties compared with natural gas and natural gas systems.

## Physical properties of natural gas

Natural gas is a colourless flammable gas (fire class C), which is odourless in its original state. For use in vehicles, natural gas is odourised, i.e. an odour added. A natural gas leak can therefore be detected before reaching the lower explosion limit.

Natural gas is lighter than air (density ratio gas/air approx. 0.6) and therefore dissipates quickly outdoors.

The explosion range is between 4Vol% and 17Vol%. Ignition temperature approx. 640°C.

Chemical formula CH<sub>4</sub>.

Methane content 79-99%.

Boiling point at 1 bar -161 ° C.

Octane number 130-140.

Energy content 1 kg: approx. 13.5 kWh.

Behavior against metals: Impurities in the gas can attack certain metals and plastics. This can lead to clogging, leaks or deposits on springs and valves.

Water content: Water is only soluble in liquid gas in very small quantities.

Flammability: Natural gas is highly flammable. Explosive / flammable vapors / air mixtures may develop during use.

# Safety devices

The entire natural gas system is installed so that it is as protected against damage as possible. The gas tanks are highly stable and extremely heat resistant. The high-pressure pipes and connecting elements are made from seamless stainless steel and extend outside the passenger compartment. The gas tanks are located under the luggage compartment floor. They are therefore as protected against damage and weather conditions as possible.

## Natural gas tank multifunction valve

All natural gas tanks are each provided with a multifunction valve. The multifunction valves for the gas tanks have an integrated thermal fuse in addition to the electromagnetic shut-off valves. They also feature a flow rate limiter which prevents an uncontrolled gas leak in the event of line damage. In the multifunctional valves for the gas tank, there is also a non-return valve fitted, which prevents the gas from the gas tank returning to the filling line.

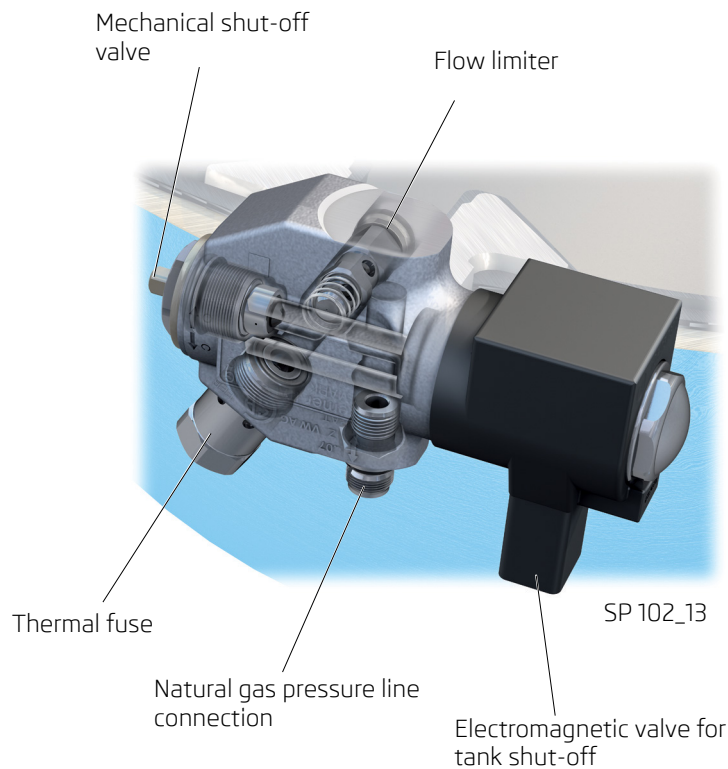

The electromagnetic valves for tank shut-off automatically interrupt the gas supply if the engine is stopped, when in petrol mode and in the event of a crash.

## Electromagnetic valve for tank shut-off

An integral component of the multifunctional valve is an electromagnetic valve for shutting off the tank. This valve is opened by the engine control unit during natural gas operation.

The valve closes automatically when switching to petrol mode, when switching off the engine, in the event of an accident that triggers the airbag and/or belt tensioners, or when there is a loss of power.

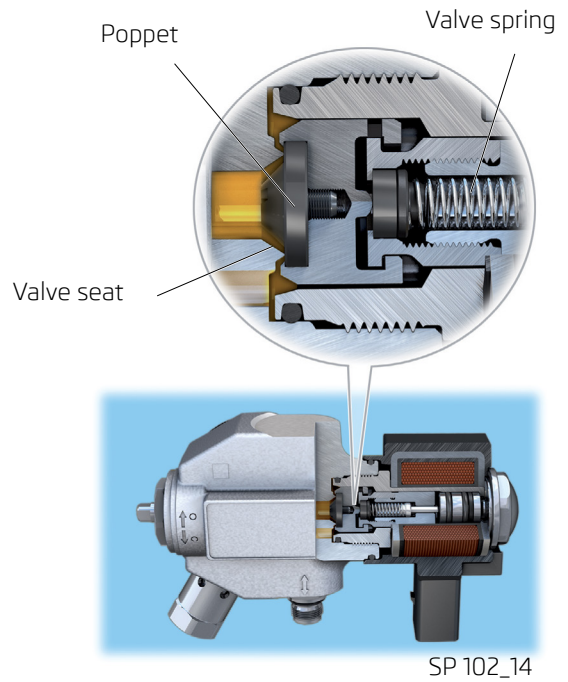

### Magnet coil is live

Due to the effect of the magnetic field, the valve plate moves against the pressure of the valve spring from the valve seat. This opens the path for the gas flow from the gas tank to the gas pressure regulator.

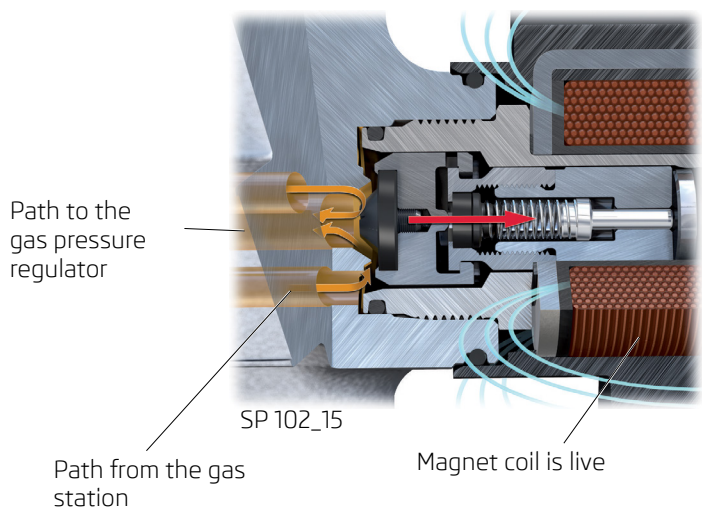

### Electromagnetic valve status in the event of natural gas

The electromagnetic valve is decoupled from the current supply during tank operation. The gas flows under pressure, which is dependent on the external temperature, and this can reach a value of approx. 260 bar. The valve plate is pressed against the valve spring by this pressure. This opens the path for the gas flow from the filler neck in the direction of the gas tank. If the pressure on both valve sides is the same, then the natural gas flow is stopped. The valve spring now pushes the valve back into the valve seat and closes the gas tank as a result.

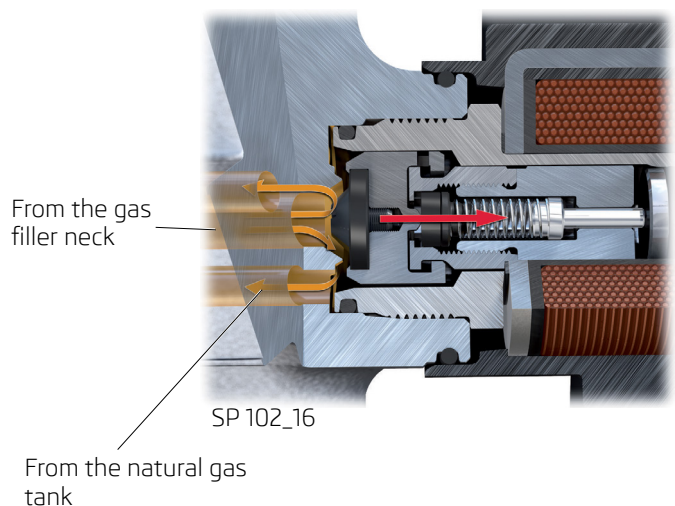

## Flow limiter

The flow rate limiter is part of the multifunction valve. There is a safety valve which is located in the connecting flange of the multifunction valve. It prevents gas from leaking from the gas tank unintentionally and suddenly as a result of damage the gas pipelines or the gas pressure regulator. The flow rate limiter prevents gas from leaking uncontrollably and reduces any possible leakage flow to max. 0.05 m<sup>3</sup>/min at 10 MPa (100 bar).

Pressing the manual stopcock > Page 74 stops the gas leak completely.

Flow limiter

Flange with threaded connection for connecting the shut-off valve to the gas tank nozzle

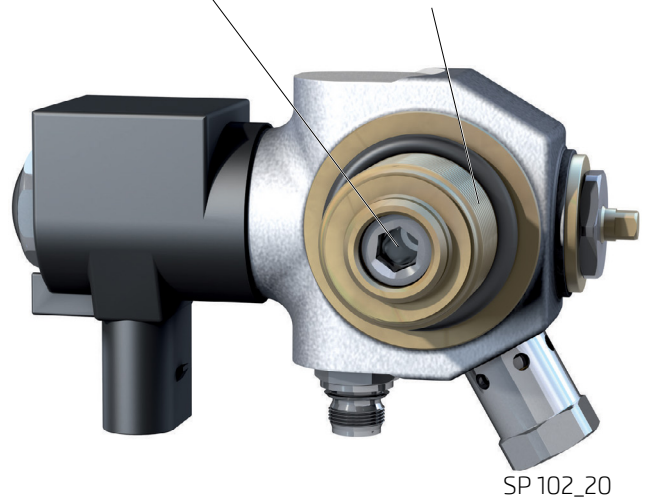

### Functional condition of the limiting valve when the high-pressure fuel line system is ok

In the normal state, the natural gas pressure behind and upstream of the flow restricting valve is approximately the same. The spring keeps the valve open.

Balanced pressure conditions upstream and downstream of the flow restrictor valve - the valve is open

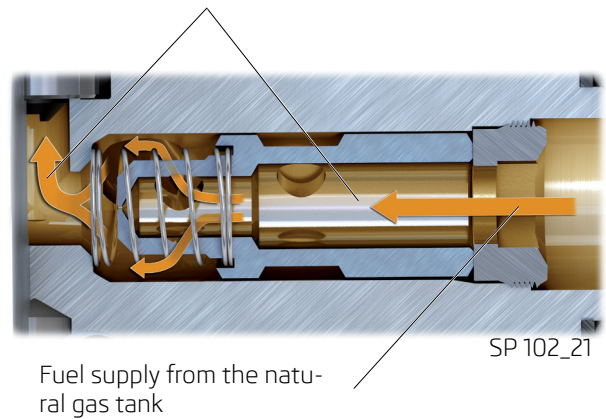

### Functional condition of the limiting valve when the high-pressure fuel line system is damaged

If, for example, a sudden pressure drop occurs due to the gas line being severed, and the natural gas pressure is increased by approx. 6.5 bar higher than behind it, the restriction valve is closed due to the different pressure conditions.

Pressure relief opening      Natural gas high pressure in the gas tank

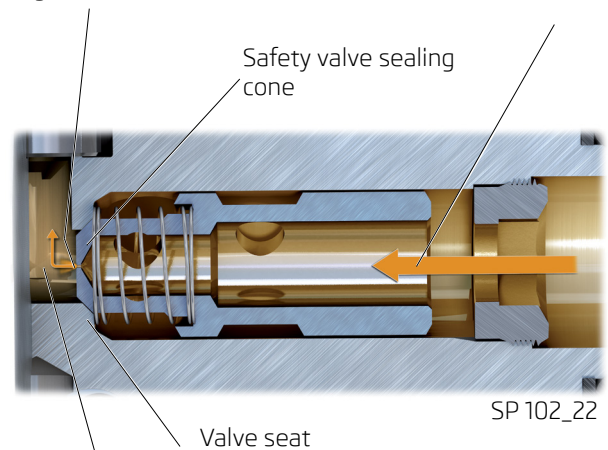

A significant reduction in natural gas pressure upstream of the flow limiting valve, for example due to a broken high pressure line



## Thermal fuse

The thermal fuse is also part of the multifunction valve. It prevents the natural gas tank from bursting due to an excessive pressure rise as a result of high temperatures. The thermal fuse is installed so that it is possible to release the natural gas directly under the vehicle.

The fuse contains special melting material. If the fuse is stressed over a certain period of time by a temperature of more than 110 °C, the melting material will start to melt. Due to the gas pressure, the securing piston moves into the exposed area after the melt material and the fuse opening into the ambient area is released. The natural gas from the gas tank starts to escape in a controlled quantity.

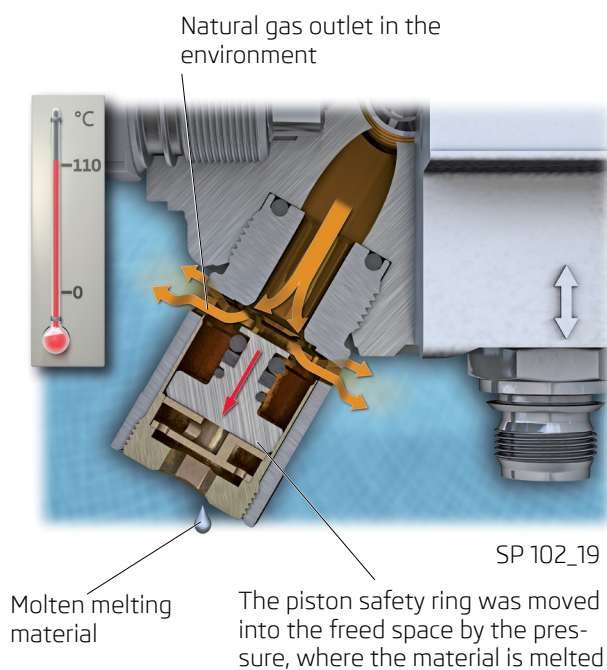
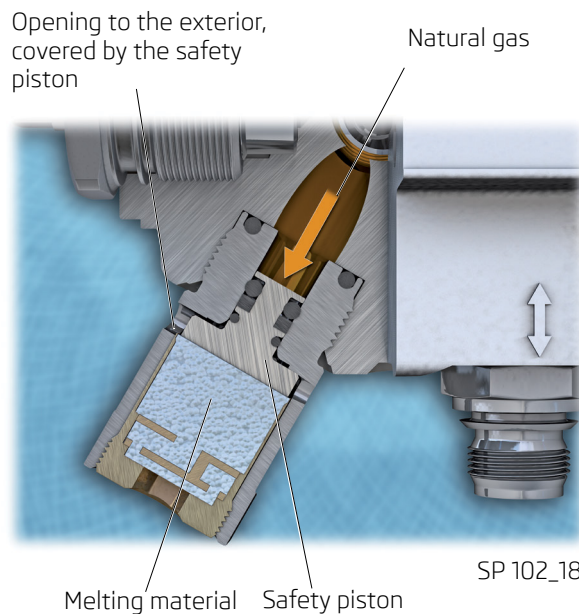

## Mechanical shut-off valve

The natural gas tank can be sealed gas-tight using the manual, mechanical shut-off valve

> Page 74. For safety reasons, this is necessary when carrying out any removal or assembly work on the natural gas tank, or when stabilising a vehicle that has been involved in an accident and may be damaged.

For safety reasons, the drain channel for thermal fuse is open even when the shut-off valve is closed.

Mechanical shut-off valve Gas channel from mechanical shut-off valve

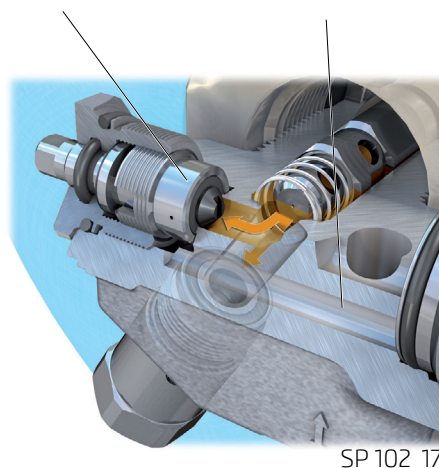



# Vehicle identification

Natural gas vehicles can be distinguished from conventionally powered vehicles by the following points:

## Sticker on the rear window

Vehicle identification using one of the CNG symbols according to relevant nat  
The marking is located in the upper right-hand corner of the rear window.



S01-10151

## Citigo vehicle marking on the tailgate

Old version:  
Lettering **CITIGO** in color.



SZ1-0009

Current version:  
Lettering **CITIGO** and **G-TEC** in color.



SZ1-0043

Additional gas filler neck under the fuel filler flap on the rear right side of the Citigo vehicle.



SP102\_5

### Octavia III vehicle marking on the tailgate

Lettering **G-TEC** in color.



SZ1-0041

Additional gas filler neck under the fuel filler flap on the rear right side of the Octavia III vehicle.



SP102\_4

# Usage instructions for a natural gas vehicle



The installation position of the relevant components of the natural gas system can be found in the rescue data-sheets.

Components of the natural gas system are marked in the rescue datasheets as follows:

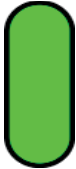

Natural gas tank



Multifunction valve

## Vehicle fire

In the event of a vehicle fire, in which the natural gas tank is also subjected to heat, the thermal fuses are activated at a temperature of about 110°C and the natural gas is definitively released, which then ignites and burns off. If the gas tank is full, it takes approx. 90 seconds for all the natural gas to be released from the tank.

As soon as no more gas is released, you can start fighting the fire in a conventional manner. If the natural gas tanks are not affected by the fire (e.g. in the event of a fire in the engine compartment), you can start fighting the fire directly.

In the event of a fire, the natural gas tanks are fitted with a protective valve that allows the expanded gas to be released in a controlled manner as soon as the temperature exceeds 110°C (even though the ignition temperature of natural gas is 537°C).



If the vehicle is lying on its side or roof, it can cause a flash fire when the thermal fuse is activated. Maintain a safe distance from the vehicle! If possible approach from the front.



If the thermal fuses have been activated, the fire should not be put out near the gas cylinder if possible until all the gas has burned off from the tank. If it is necessary to put out the fire (e.g. to rescue people), prevent a build-up of natural gas in confined spaces (e.g. implement ventilation measures, release natural gas).



You can recognise the thermal fuse being triggered by the loud hissing noise.

## Traffic accident/gas outlet on a natural gas vehicle

The risk that the natural gas will leak as a result of an accident is extremely low as several safety devices must fail at the same time.

Generally, the following measures should be taken after an accident (as with all ŠKODA brand vehicles):

- Switch off the ignition
- Disconnect the battery



**For rescue work on a natural gas vehicle, proceed according to the following provisions:**

**Application order for the Fire Rescue Service - tactical procedures**

Title: **Natural gas and LPG vehicles, implementation provision number 5 D**

Issued on: 12 December 2012, Ministry of the Interior - Directorate General of the Česká republika district Fire Rescue Committee

If it is determined that there is a natural gas leak at the scene of an accident (e.g. due to the smell of gas), the following measures should be taken:

- Switch off the engine
- Switch off the ignition
- Clear and seal off the danger area
- Do not start the vehicle, if necessary, rescue passengers through the windows in enclosed rooms
- Ventilate the vehicle interior (open the doors, windows, bonnet and luggage compartment lid)
- Determine the gas concentration, note any accumulation in cavities
- Ensure there is cross ventilation, "release" the natural gas with fan
- Remove sources from the vehicle that may cause a fire (e.g. disconnect the vehicle battery, mobile phones in the vehicle interior)
- If necessary, close the gas tanks using the mechanical shut-off valves > page 74



In the event of a natural gas leak, the gas flows into the atmosphere and there is no risk of a dangerous accumulation above the ground (as is the case with a LPG leak).

In the event of critical gas concentration > page 64, If the lower natural gas explosion limit of 20% has been reached, disconnecting the battery should be dispensed with as long as no accompanying preventive measures, e.g. venting using overpressure ventilation, are carried out.

## ŠKODA Citigo vehicle natural gas tanks



Gas tank behind the rear axle

Gas tank in front of the rear axle

SZ1-0035

## Natural gas tank of the ŠKODA Octavia III vehicle



Natural gas tank behind the rear axle

SZ1-0049

Absorption for gas tanks

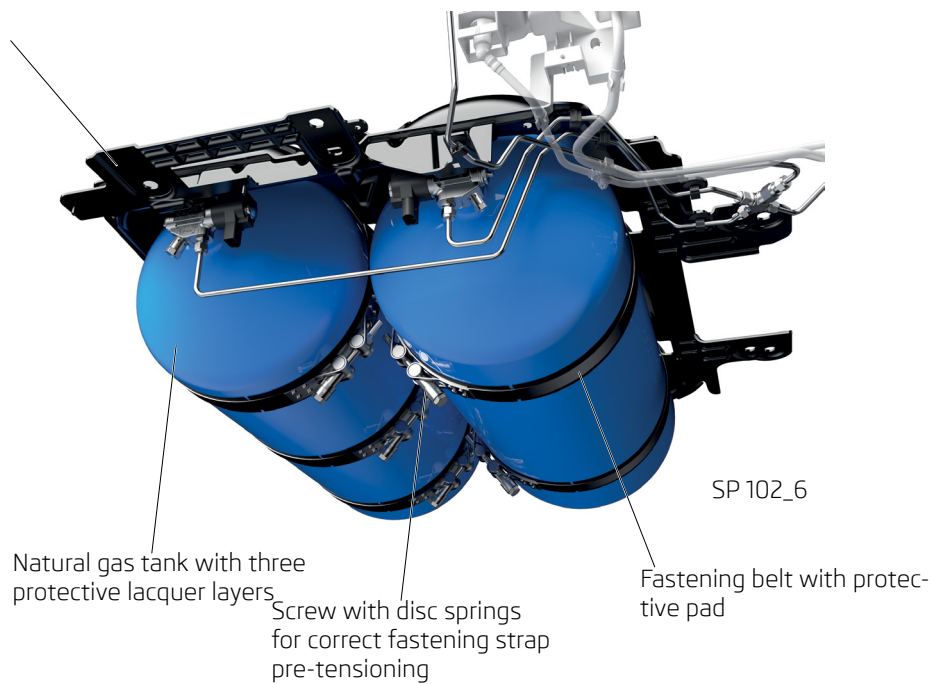

Fig. Fitting natural gas tanks to the ŠKODA Octavia III vehicle



## Manually close valves on the gas tanks

If required, the shut-off valves can be manually closed on the gas tanks as follows.

### ŠKODA Citigo vehicles

Raise the rear of the vehicle so that the covers for the natural gas tank are accessible.

Unscrew the plastic nuts (see arrows) on the cover for the natural gas tank behind

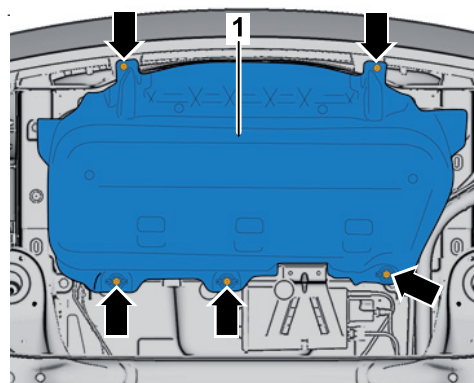

Unscrew the plastic nuts (see arrows) on the cover for the natural gas tank in front of the rear axle and remove the cover.

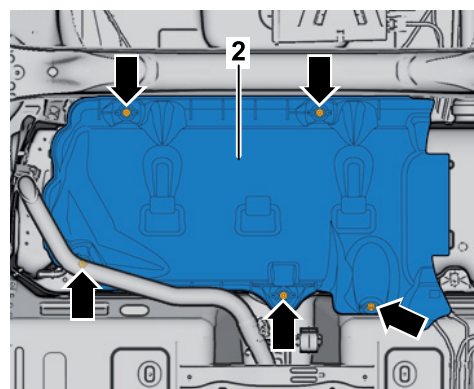

Use the handwheel -T50026- (ŠKODA special tool) or pliers to close the shut-off valves on both natural gas tanks in the direction of the arrow shown.

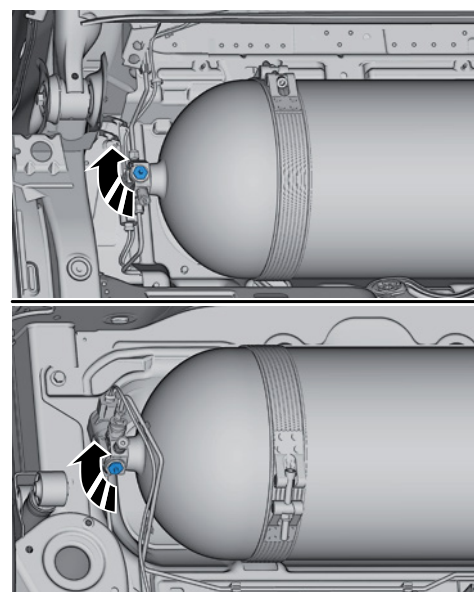



## ŠKODA Octavia III vehicles

Raise the rear of the vehicle so that the covers for the natural gas tank are accessible.

Loosen the plastic nuts A and B (see arrows) of the natural gas tank cover and remove the cover.

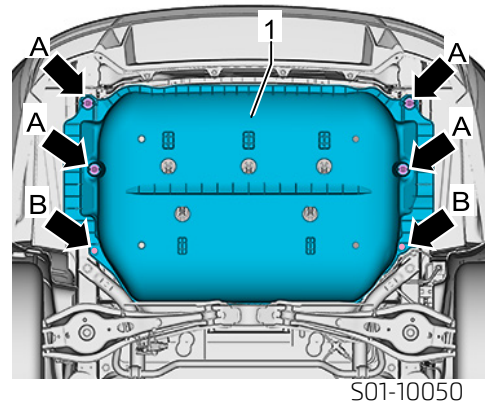

Use the handwheel -T50026- (ŠKODA special tool) or pliers to close the shut-off valve (N361) on the rear natural gas tank in the direction of the arrow shown.

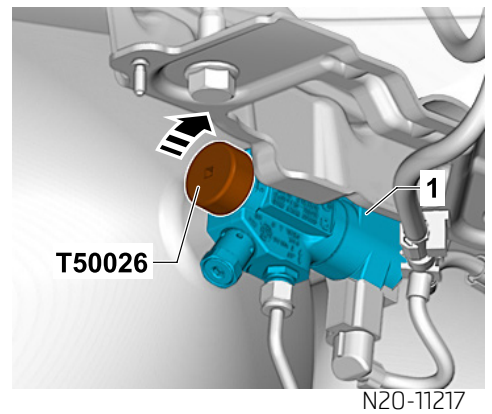

Use the handwheel -T50026- (ŠKODA special tool) or pliers to close the shut-off valve (N362) on the front natural gas tank in the direction of the arrow shown.

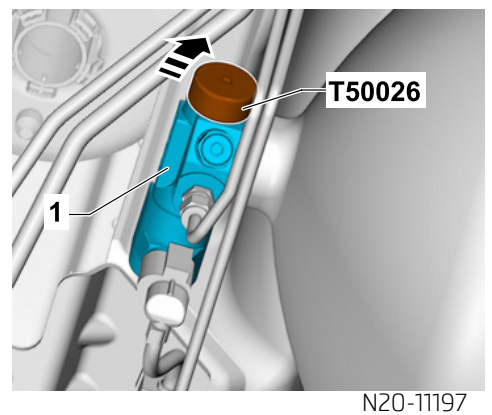

**ŠKODA Octavia III Facelift vehicles (from 01/2019 onwards)**  
**Manually closing off fuel tank 3**

Raise the rear of the vehicle so that the natural gas tank cover panels are accessible.

Unscrew the nuts (see arrows) and remove the cover panel -1-.

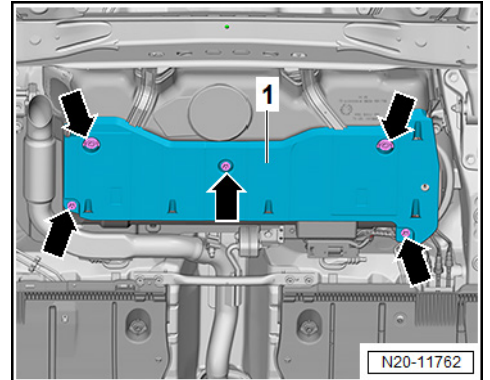

Unscrew the nut -2-.  
Remove the cover panel -1- and pull it out over the cables -3- (see arrow).

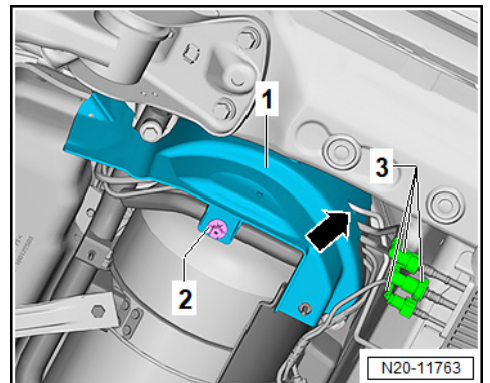

Close the mechanical shut-off valve -2- by turning it clockwise using the handwheel -T50026- (special Škoda tool) or an alternative tool such as a pair of pliers.

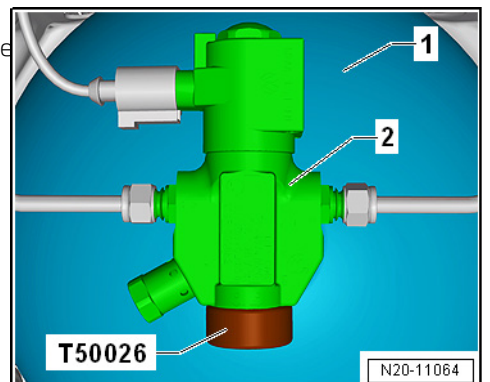

## ŠKODA SCALA and KAMIQ vehicles Manually closing off the fuel tanks

Raise the rear of the vehicle so that the natural gas tank cover panels are accessible.

Closing the tank shut-off valves 1 and 2:

Unlock the turn-lock fasteners and remove the side cover -1- (see arrows) for the natural gas tanks 1 and 2.

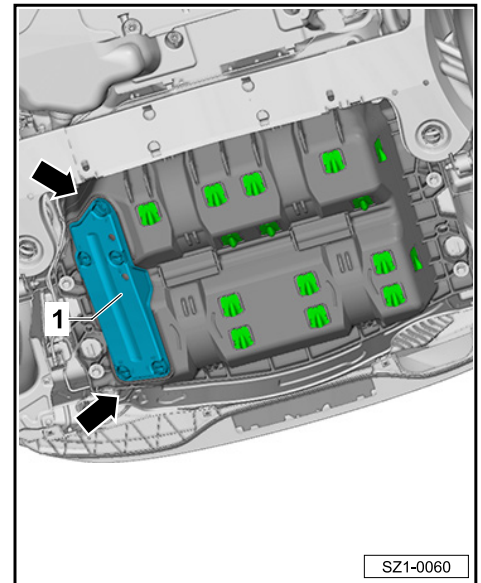

Close the mechanical shut-off valves -1- and -2- one after the other by turning them the handwheel -T50026- -A- (special Škoda tool) or an alternative tool such as a pair of pliers.

Closing the tank shut-off valve 3:

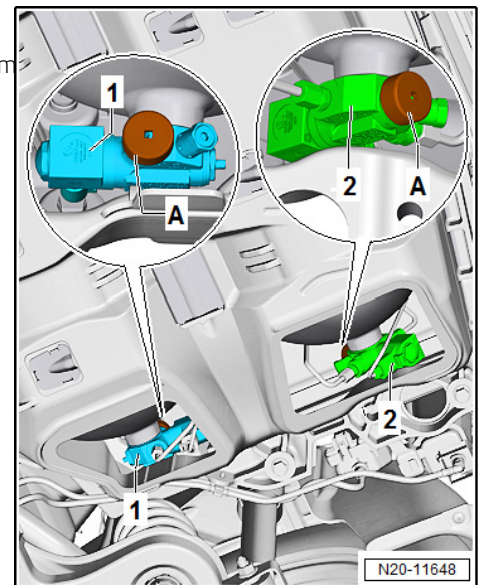

Unlock the turn-lock fasteners -2- for the natural gas tank 3.  
Remove the cover panel -1- for the natural gas tank 3.

Move the tailpipe down and out of the way.

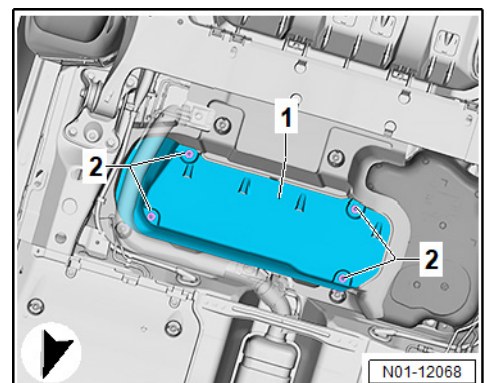

Close the mechanical shut-off valve -2- by turning it clockwise using the handwheel  
-T50026- (special Škoda tool) or an alternative tool such as a pair of pliers.

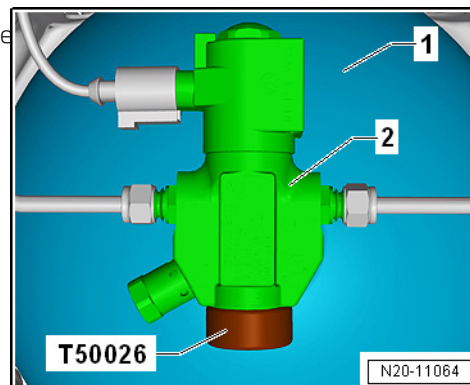

# LPG vehicles

LPG vehicles differ in some respects from conventional vehicles. It is very important that rescue personnel understand these differences in the event of a rescue effort.

The ŠKODA factory manufactures some models powered by LPG.

All ŠKODA LPG-powered vehicles can either run on LPG or petrol.

LPG-powered vehicles are driven primarily by LPG; the fuel tank is only used as a reserve.

Dealing with LPG vehicles is no more dangerous than dealing with petrol or diesel vehicles, but there are some differences.

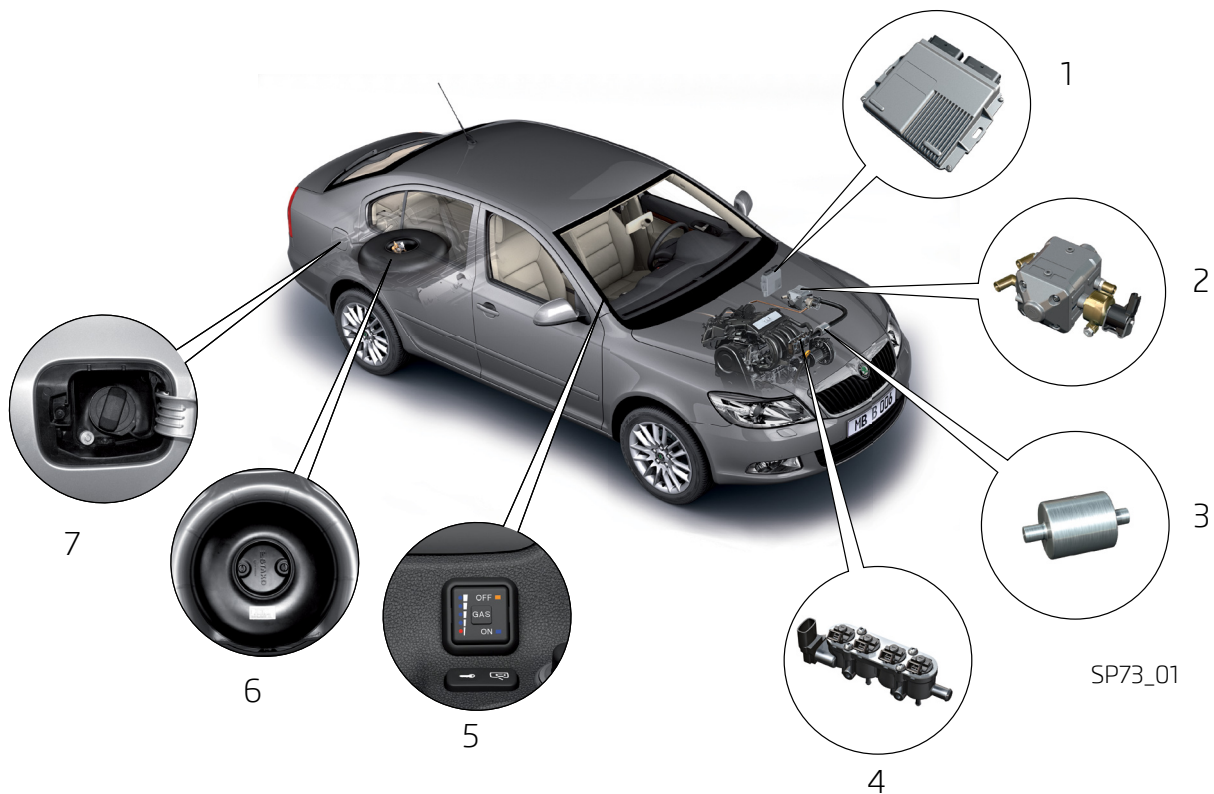

1. Control unit for LPG operation
2. Evaporator with electromagnetically controlled high-pressure valve for LPG operation
3. Gas filter
4. Gas distributor rail with gas injectors and sensor for gas distributor rail
5. Fuel-type switcher and level indicator
6. LPG tank with integrated multifunction valve
7. LPG filling connection

## Physical properties of LPG (liquefied petroleum gas)

LPG consists of hydrocarbons that are easy to liquefy with three or four carbon compounds (fire class C), mainly propane ( $C_3H_8$ ), butane ( $C_4H_{10}$ ), propylene ( $C_3H_6$ ) and butylene ( $C_4H_8$ ).  
For use in vehicles, LPG is odourised, i.e. an intensive odour is added.

When a gas, LPG is heavier than air (density ratio LPG/air approx. 1.55) and therefore spreads on the floor.

LPG is liquefied at a pressure of 8 bar, which significantly reduces the volume (1/260 part of the original volume).  
Explosion range between 1.4 and 10.9Vol %.  
Ignition temperature approx. 460 °C.



LPG (also referred to as liquefied petroleum gas) must not be confused with natural gas (CNG – compressed natural gas). Natural gas and natural gas systems have different fundamental properties compared with LPG and LPG systems.



# Safety devices

The entire LPG system is installed so that it is protected against damage as much as possible. The gas tank is highly stable and heat resistant. All high-pressure pipes and connecting elements are made of stainless steel or copper and principally extend outside the passenger compartment. On the inside, the tank is protected from damage and weather conditions as far as possible. The tank is fitted with a multifunction valve with safety functions.

## Multifunction valve for LPG tank

The LPG tank is fitted with a multifunction valve. The multifunction valve has a safety relief valve in addition to the electromagnetic shut-off valve. It also has a flow rate limiter which prevents an uncontrolled gas leak in the event of line damage. In the multifunction valve, there is also a stop valve fitted with a check valve, which prevents the gas from the gas tank returning to the filling line.

The electromagnetic valve for tank shut-off automatically interrupts the gas supply if the engine is stopped, when in petrol mode and in the event of a crash.

## Valve for tank shut-off

An integral component of the multifunctional valve is an electromagnetic valve for shutting off the tank.

This valve is opened by the gas control device during LPG operation.

The valve closes automatically: when switching to petrol mode, when switching off the engine, in the event of an accident that triggers the airbag and belt tensioners, or when there is a loss of power.

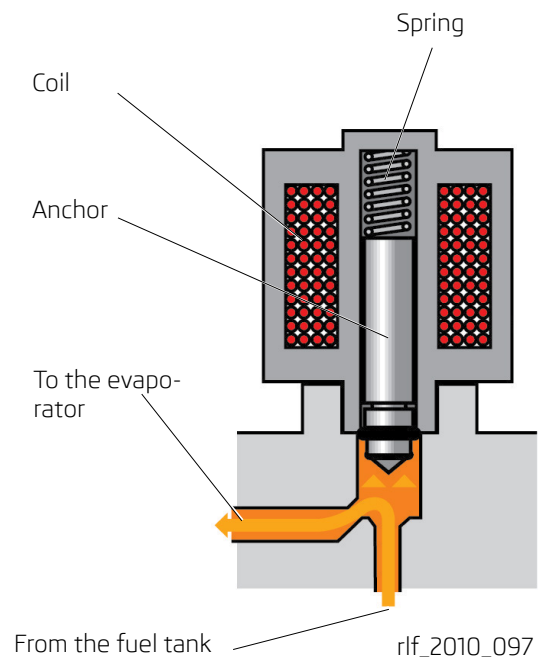

## Safety pressure relief valve

The safety valve is part of the multifunction valve, which is installed on the LPG tank. It prevents the LPG tank from bursting as a result of an excessive pressure rise, e.g. as a result of high temperatures. The safety pressure relief valve is installed so it is possible to release the LPG from the tank outside the passenger compartment. The safety pressure relief valve is pressure-controlled, i.e. it opens when the pressure in the tank exceeds 27.5 bar. If the overpressure reduces, the valve closes again thanks to its design.

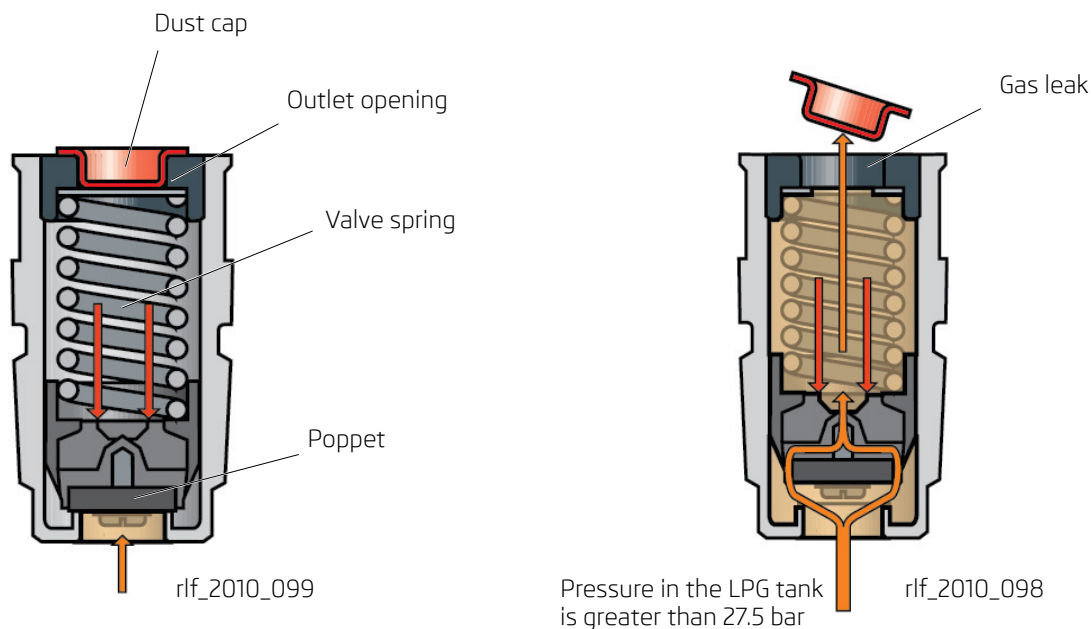

As soon as the pressure in the LPG tank exceeds 27.5 bar, the relief valve opens and blows the LPG in the area of the multifunction valve. From here, the LPG is guided through a plastic ventilation pipe below the rear of the vehicle.

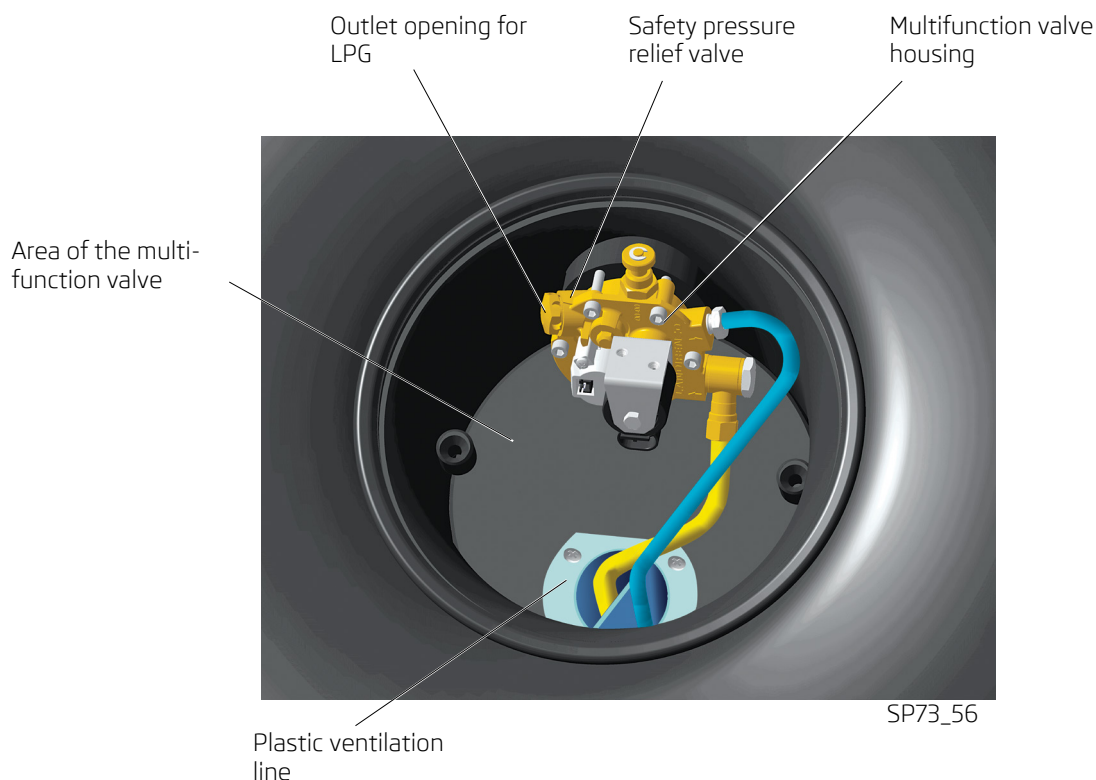

# Vehicle identification

LPG vehicles can be distinguished from conventionally powered vehicles by the following points:

Vehicle identification using one of the LPG symbols according to relevant national rules (only valid in a few countries). The marking is located in the upper right-hand corner of the rear window.



SZ1-0011



SZ1-0012

Coloured "MPI" lettering on the luggage compartment lid.



SZ1-0013

Additional gas filler tubes below the fuel filler flap on the rear right-hand side of the vehicle.



SZ1-0014

# Usage instructions for an LPG vehicle



The installation position of the relevant components of the LPG system can be found in the rescue datasheets. Components of the LPG system are marked in the rescue datasheets as follows:

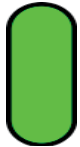

LPG tank



Multifunction valve

## Vehicle fire

In the event of a vehicle fire, in which the LPG tank is also subjected to heat, the pressure relief valve is activated at a pressure of 27.5 bar, and the LPG is definitively released, which then ignites and burns off. If the LPG tank is not affected by the fire (e.g. in the event of a fire in the engine compartment), you can start fighting the fire directly.



If the vehicle is lying on its side or roof, it can cause a flash fire when the pressure relief valve is activated. If the vehicle is on its wheels, the gas flow below the LPG tank is guided vertically towards the ground. Maintain a safe distance from the vehicle. If possible approach from the front.



As far as possible, cool the gas tank outside the cover to avoid it heating up to a point where the pressure relief valve is triggered. Continue cooling the tank, even if the pressure relief valve is triggered.



You can recognise the pressure relief valve being triggered by the loud hissing noise.

## Traffic accident/gas outlet on a LPG vehicle

The risk that the LPG will leak as a result of an accident is extremely low as several safety devices must fail at the same time.

Generally, the following measures should be taken after an accident (as with all ŠKODA brand vehicles):

- Switch off the ignition
- Disconnect the battery
- Disconnect the trailer electricity supply



**For rescue work on an LPG vehicle, proceed according to the following provisions:**

**Application order for the Fire Rescue Service - tactical procedures**

Title: **Natural gas and LPG vehicles, implementation provision number 5 D**

Issued on: 12 December 2012, Ministry of the Interior - Directorate General of the Česká republika district Fire Rescue Committee

If it is determined that there is an LPG leak at the scene of an accident (e.g. due to the smell of gas), the following measures should be taken:

- Switch off the engine
- Switch off the ignition
- Clear and seal off the danger area
- Do not start the vehicle, if necessary, rescue passengers through the windows in enclosed rooms
- Ventilate the vehicle interior (open the doors, windows, bonnet and luggage compartment lid)
- Determine the gas concentration, note accumulation in lower-lying areas
- Ensure there is cross ventilation, "release" the LPG with fan
- Remove sources from the vehicle that may cause a fire (e.g. disconnect the vehicle battery, mobile phones in the vehicle interior)
- If necessary, close the fuel tank using the mechanical shut-off valve > Page 86



Avoid disconnecting the battery if there is a critical gas concentration > Page 80.



SZ1-0015

Fig. LPG tank in the spare wheel well under the luggage compartment floor.



## Closing the LPG tank

Loosen the screws for the protective cover of the multifunction valve - (see arrows) and the cover (pos. 1).

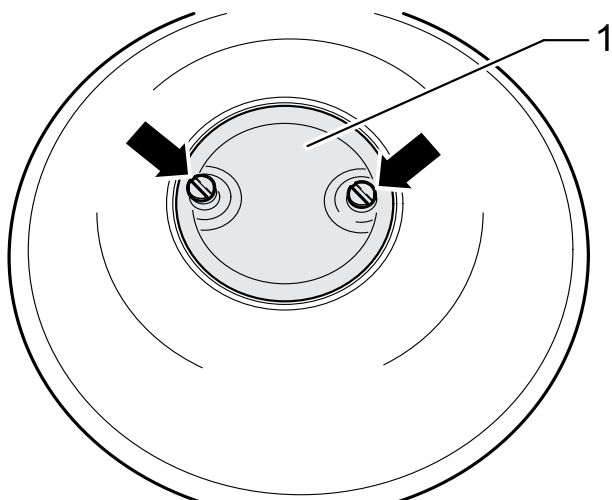

S02-0567

Close the mechanical shut-off valve (pos. 1) on the multifunction valve by turning it clockwise until the stop.

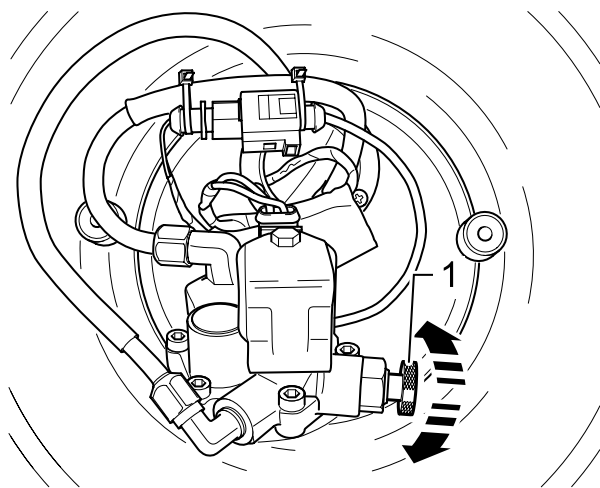

S02-0616

# BEV electric vehicles and PHEV hybrid vehicles

## Octavia Green E Line II electric car



SZ1-0025



SZ1-0026

An electric vehicle is driven by an electric machine, which is supplied by a high-voltage battery. The electric machine drives the vehicle accessories in a similar manner to an internal combustion engine. The electric vehicle has a 12 V battery, which supplies the electrical system and the control systems of the vehicle with current.

The high-voltage battery is charged via an integrated 220/380 V adapter. The adapter connectors are located beneath the tank flap and on the lock cross-member.



The Li-ion high-voltage battery operates in a voltage range of up to 360 V.



Improper handling of high-voltage components can be fatal due to the high voltage and the resulting potential current flow through the human body.

## High-voltage components

The high-voltage lines are covered with orange insulation.



SZ1-0027



The yellow warning label indicates the high-voltage components that are installed near the label or hidden below covers.



The red warning sticker labelled "**DANGER**" directly indicates the high-voltage components.

If used incorrectly, the high-voltage system may pose a threat. Therefore, the Octavia Green E Line II electric car is fitted with a comprehensive security concept that includes all components for the high-voltage system, i.e.:

- E-engine
- Power electronics
- High-voltage lines
- High-voltage battery



The high-voltage components, including the orange high-voltage lines, may only be repaired, maintained or serviced by properly trained professionals. Unauthorised work on the high-voltage system is prohibited!

## High-voltage battery

The high-voltage battery features a Saft brand Lithium-Ion (Li-Ion) battery with a voltage of up to 360 V. It is located under the vehicle floor in the middle and then also under the luggage compartment floor. The high-voltage battery consists of interconnected cells. Each cell is integrated into the system by the control electronics.

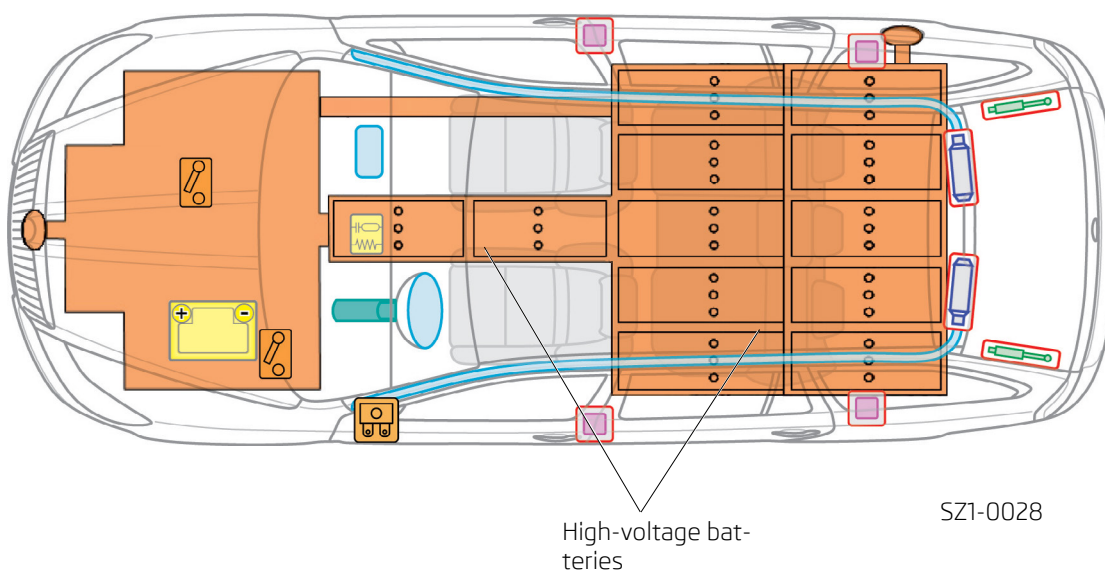

### Icon illustration of the components relevant for use.



Fuse box



High-voltage line/component



High-voltage battery



High-voltage disconnecting point



The installation position of the relevant components of the high-voltage system can be found in the rescue datasheets.

## Vehicle identification

**Green  Line**  
ELECTRIC CAR

On the doors and the luggage compartment lid.

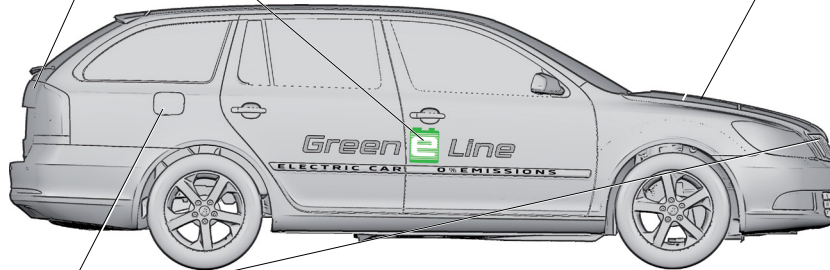

  
ELECTRIC CAR

On the front flap.

SZ1-0029



Sticker on the lock cross-member and on the fuel filler flap/charge box cover.

## Preventing the vehicle from rolling away

Secure the vehicle from the outside, e.g. use wedges to prevent vehicle rolling away.

Secure the vehicle from the inside using the handbrake.



SZ1-0003

For vehicles with automatic transmission, move the selector lever to position "P".



SZ1-0004

## Interrupting the charging power supply

The charging power supply to the vehicle must be disconnected at the vehicle or the charging station/charging socket.

## Disconnecting the charger cable from the vehicle

Lock the vehicle, then unlock it (with ignition key or remote control). This unlocks the car charger on the vehicle. Disconnect the charge plug from the vehicle within 30 seconds. The charging sockets are located under the flap and on the lock cross-member.

## Disconnecting the charger cable from the charging station/charging socket

Interrupt the charging process by unplugging the charging plug.

## Deactivating the high-voltage system and drive



In the event of an accident when the airbags are triggered, the high-voltage system is automatically deactivated (the high-voltage battery is disconnected).



Even after deactivating the high-voltage system, there may still be power in the high-voltage battery. The high-voltage battery must not be damaged or opened. The high voltage system may also be deactivated in accordance with the following instructions from the inside or via the engine compartment.



## Deactivating the high-voltage system and drive from the inside

(Ignition and fuse carrier accessible)



SZ1-0005

1. Turn the ignition key to the left and remove it if possible.



Safety systems such as airbags and belt tensioners are deactivated in max. 4 seconds after switching off the ignition.

Before this time has elapsed, there is a risk of the airbag being triggered as a result of possible damage to the airbag system. In some cases, the airbags and belt tensioners may also be triggered after this time due to an electrostatic charge.



SZ1-0030

2. Open the driver's door and remove the cover on the left-hand fuse box.



SZ1-0031

3. Remove the specially marked red fuse no. 38 (5. row from above, penultimate fuse from the left).



After 15 seconds, the high-voltage system is de-energised. During this time, there is a risk of electric shock. The other systems (low-voltage systems) continue to be supplied with voltage by the 12 V battery. Systems that are supplied with voltage when the ignition is switched on, such as airbags and belt tensioners, are de-energised.

## Deactivating the high-voltage system and drive from the engine compartment

(Engine compartment accessible)



SZ1-0032

1. Locate the access to the earth connection of the 12 V battery.

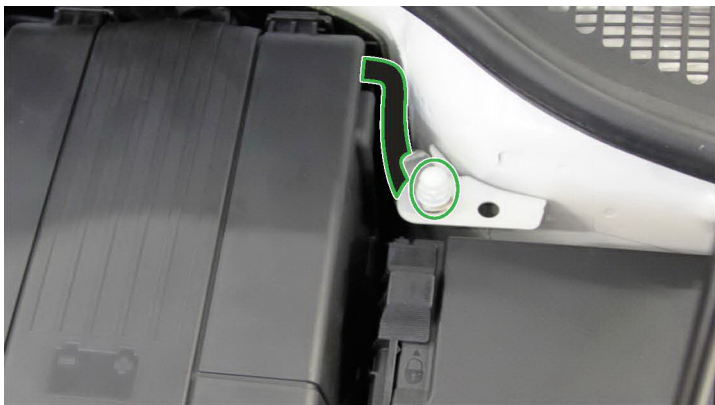

SZ1-0006

2. Disconnect the earth connection.  
> Unscrew the earth-connection nut and remove the earth wire  
or  
> Disconnect the earth wire.



SZ1-0033

3. Locate the 12 V positive power cable in the power electronics with the yellow dividing marker.

# ŠKODA Citigo-e iV vehicle

## Identification and distinguishing features

The Citigo-e iV is an electric vehicle and features the Citigo e logo on the boot lid.



SZ1-0061



## Drive system

This vehicle is fully electric; its design is comparable to the Citigo front-wheel drive.



SZ1-0062

## Changes and modifications to the vehicle body

### Additional B-pillar reinforcement

In the vehicle body, the B-pillar has been reinforced to meet the specific crash safety requirements. It is the only component in the vehicle body to have a different geometry and material to that of the Citigo.



SZ1-0067

### Underbody

Due to the high-voltage battery installed in the Citigo-e iV, the mid-section and centre rear of the underbody has had to be redesigned. It was important that the underbody should meet the crash safety requirements. To protect it from damage and corrosion, the Citigo-e iV is fitted with an underbody cover panel. The underbody cover panel is attached to the high-voltage battery's lower shell section and the side members.



SZ1-0068



SZ1-0069



## Installation positions of the high-voltage components

The high-voltage cables are encased in orange insulation.



SZ1-0066

In the Citigo-e iV, there are warning labels on the bonnet lock bracket and on all high-voltage components, indicating the risks associated with the electric drive system.

The red warning labels that say "**DANGER**" are applied directly to high-voltage components.



Improper use or handling of the high-voltage system can be dangerous. For this reason, the electric vehicle has an integrated safety concept that incorporates all the components of the high-voltage system, i.e.:

- Electric motor
- Power electronics
- High-voltage cables
- High-voltage battery



High-voltage components and the orange high-voltage cables must always be repaired, maintained and serviced by qualified personnel with the appropriate training. Unauthorised work on the high-voltage system is prohibited.

## Installation position of the Citigo-e iV's 12-volt battery

The 12-volt battery is located in the engine compartment, similar to vehicles with conventional drive systems.



SZ1-0063

## Installation position of the high-voltage battery, variant, technical characteristics

A 1 AX2-type high-voltage lithium-ion battery is installed in the vehicle. The battery is located in the centre of the vehicle's underbody. The advantages of this are:

- The low centre of gravity
- The optimal weight distribution

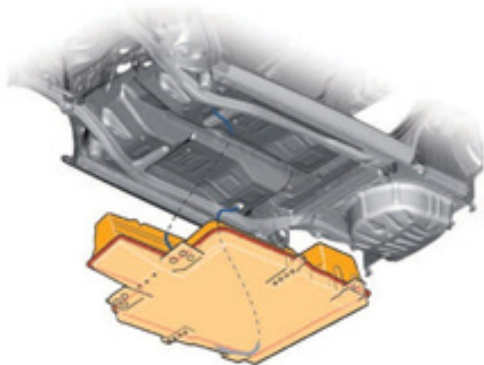

SZ1-0064

## High-voltage battery casing

The high-voltage battery is secured in a casing underneath the vehicle. The casing consists of two main parts: The upper and the lower shell sections. The upper shell section is made of plastic; to meet the EMC requirements, it is coated with aluminium. The pressure equalisation elements are part of the upper shell section. The lower shell section is made of metal. The mounting rails for the battery cell pairs and the crash safety crossmembers are part of the lower shell section. The upper and lower shell sections are screwed together and bonded with adhesive. Once the bonding process is complete, a leak test is conducted to make sure that water cannot enter and gas cannot escape. The potential between the casing and the vehicle is equalised by means of two earth connections to the vehicle.



## High-voltage battery

The battery consists of 2 x 102 compact battery cell pairs connected in parallel. All cells are housed in one and the same casing and are installed on the vehicle's underbody as a single unit.

Weight	230 kg
Number of cells	204 cells, 2 x 102 battery cell pairs connected in parallel
Cell type	Lithium-ion, 3.75 V, 25 Ah
Nominal voltage	374 V
Capacity	50 Ah
Nominal energy	18.7 kWh
Operating range	-30 °C to +50 °C; where temperatures fall outside of this range, the output is reduced or even completely stopped.
Battery cell chemistry	Lithium-ion battery pack with nickel, manganese and cobalt oxide

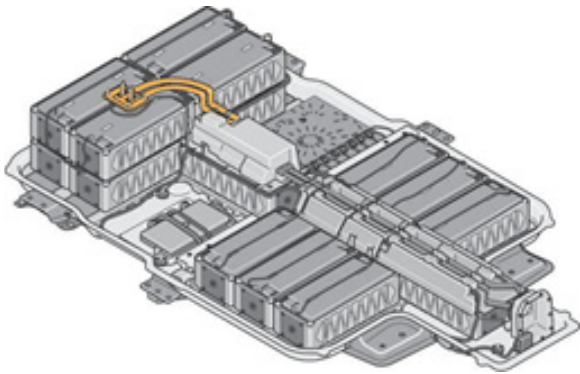

SZ1-0065

## Deactivating the vehicle's high-voltage system

### Deactivating the high-voltage system in the engine compartment

1. Locate the disconnection point for the high-voltage system in the engine compartment.



SZ1-0070

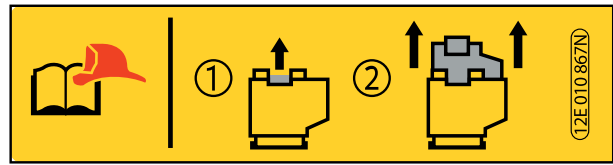

SZ1-0073

2. Press the tab on the fuse in the direction of the arrow.  
3. Pull out the fuse as far as it will go (see arrow).  
This disconnects the high-voltage system's control line.

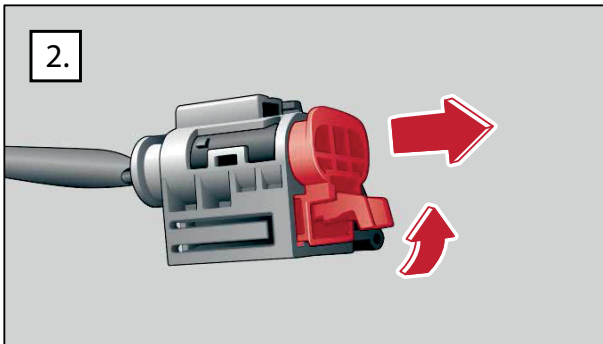

SZ1-0071

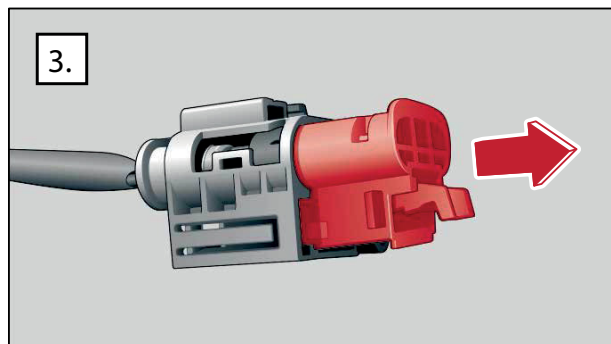

SZ1-0072

### Deactivating the high-voltage system in the vehicle interior

Locate the disconnection point for the high-voltage system in the fuse box inside the passenger compartment. Remove the cover from the fuse box and then remove the fuse with the yellow tag (see arrow). This disconnects the high-voltage system's control line.



SZ1-0074

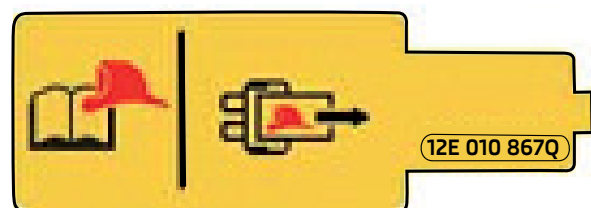

SZ1-0075

## Disconnecting the charging current supply

The charging current supply to the vehicle must be disconnected either at the vehicle or at the charging station/charging socket.

### Disconnecting the charging cable at the vehicle

Use the ignition key or remote control to lock and then unlock the vehicle; this unlocks the charging plug in the vehicle. Remove the charging plug from the vehicle within 30 seconds. The charging port is located underneath the fuel flap.

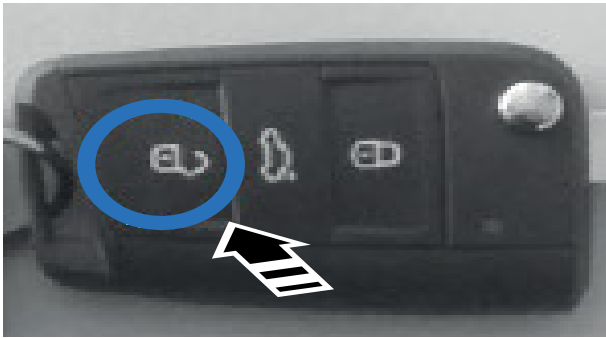

SZ1-0092

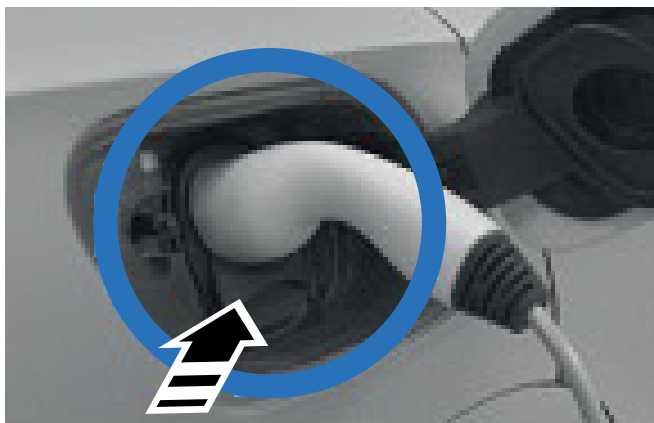

SZ1-0093

### Disconnecting the charging cable at the charging station/charging socket

Remove the charging plug to stop the charging process.

# ŠKODA Superb PHEV Hybrid vehicle

## Identification and distinguishing features

The Superb iV is a hybrid vehicle and features the Superb iV logo on the boot lid.



SZ1-0076



## Drive system

The Superb iV is a plug-in hybrid vehicle. "Plug-in" means that the high-voltage battery can additionally be recharged via an external power source. This means that it benefits from two drive strategies:

- A combustion engine
- An electric drive system



SZ1-0077

The drive unit consists of a petrol combustion engine, a three-phase AC drive system and a traction battery. This unit also has a six-speed dual-clutch transmission.



SZ1-0081

## Changes and modifications to the vehicle body

### Underbody

The Superb iV's floorpan (MQB-B) has been modified to take into account the different position of the fuel tank and to accommodate the high-voltage battery. To protect the vehicle body in the event of a traffic accident, there is a doubler in the side member at the rear. In addition, the material thickness of the parts of the inner bottom members has been increased to 2 mm. To allow the high-voltage battery to be secured to the underbody, the crossmembers beneath the underbody have been modified. Additional reinforcements have been welded to the front of the centre tunnel to provide protection in the event of a head-on collision.

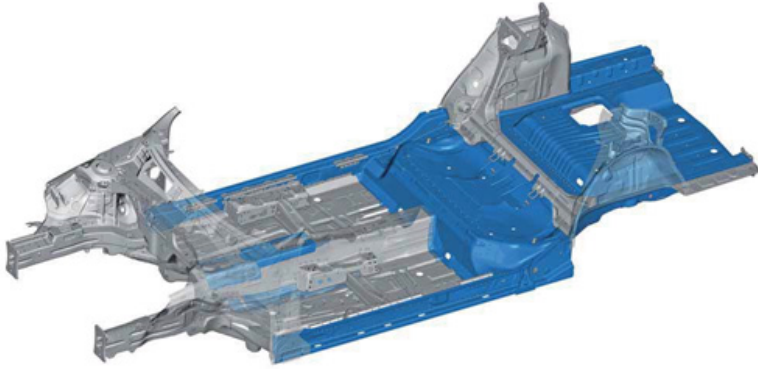

SZ1-0078

Components that have been changed compared to the Superb's original body are shown in blue in the graphic above.

#### **These components are as follows:**

- Reinforcements to the centre tunnel
- Inner bottom beam
- Front of the luggage compartment floor with a crossmember
- Rear of the luggage compartment floor, including the right-hand section of the floor
- Crossmember on the floor
- Additional doublers in side member at the rear

### High-voltage battery casing

The body-based battery protection concept manifests itself as a battery skid plate. The battery skid plate is made from four different materials combined in a sandwich-type construction. This combination was necessary due to the proximity to the exhaust system, as well as the possibility of extreme temperature fluctuations.

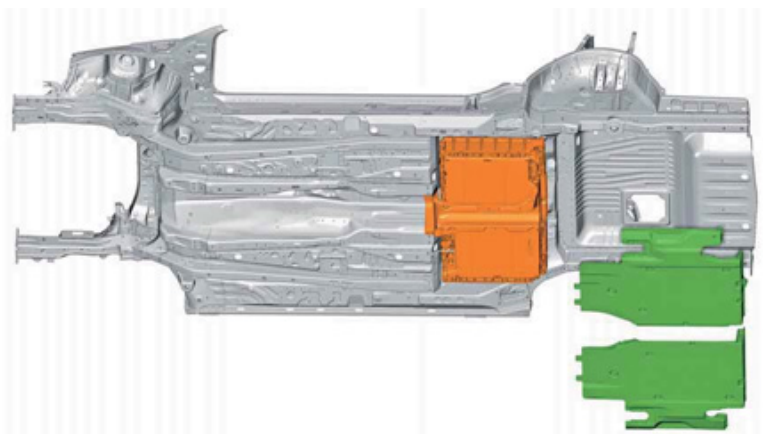

SZ1-0079



## Installation positions of the high-voltage components

The high-voltage cables are encased in orange insulation.



SZ1-0080

In the Superb iV, there are warning labels on the bonnet lock bracket and on all high-voltage components, indicating the risks associated with the electric drive system.

The red warning labels that say "**DANGER**" are applied directly to high-voltage components.



Improper use or handling of the high-voltage system can be dangerous. For this reason, the electric vehicle has an integrated safety concept that incorporates all the components of the high-voltage system, i.e.:

- Electric motor
- Power electronics
- High-voltage cables
- High-voltage battery



High-voltage components and the orange high-voltage cables must always be repaired, maintained and serviced by qualified personnel with the appropriate training. Unauthorised work on the high-voltage system is prohibited.



## Installation position of the Superb iV's 12-volt battery

In the Superb iV, the 12-volt battery is located in the left-hand side of the luggage compartment. It is a conventional lead-acid battery.



SZ1-0082

## Installation position of the high-voltage battery, variant, technical characteristics

The 1 AX2-type high-voltage battery in the Superb iV is installed on the underside of the vehicle, upstream of the rear axle. Due to the vehicle's weight, to achieve the required dynamics, the capacity of the battery cells has been increased from 25 Ah to 28 Ah. It supplies the following high-voltage equipment:

- VX54 three-phase AC drive system
- Z115 high-voltage heater
- V470 electric AC compressor



SZ1-0083

### Technical data

Weight	125 kg
Battery technology	Lithium-ion cells
Number of battery cells	96
Cell modules	8x12
Capacity	28 Ah
Nominal voltage	345 V
Capacity	9.9 kWh (gross)
Cell voltage	3.6 V (nominal)
Cooling system	Liquid cooling
Operating range	-28 °C to +60 °C
Protection classes	IP6K6, IP6K7, IP6K9K

## Deactivating the vehicle's high-voltage system

### Deactivating the high-voltage system in the engine compartment

1. Locate the disconnection point for the high-voltage system in the engine compartment.

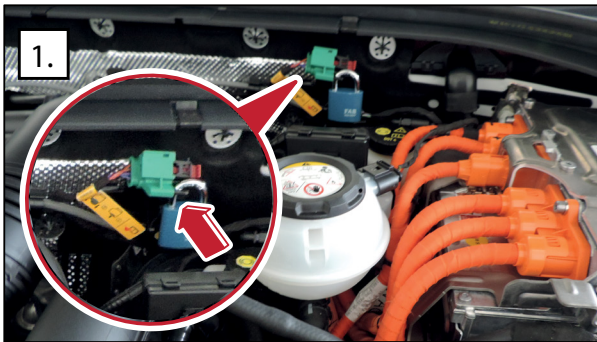

SZ1-0084

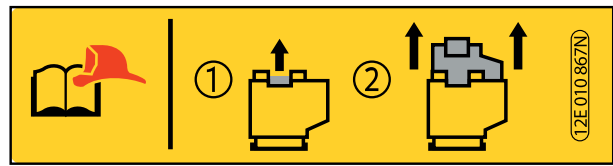

SZ1-0088

2. Press the tab on the fuse in the direction of the arrow.  
3. Pull out the fuse as far as it will go (see arrow).  
This disconnects the high-voltage system's control line.

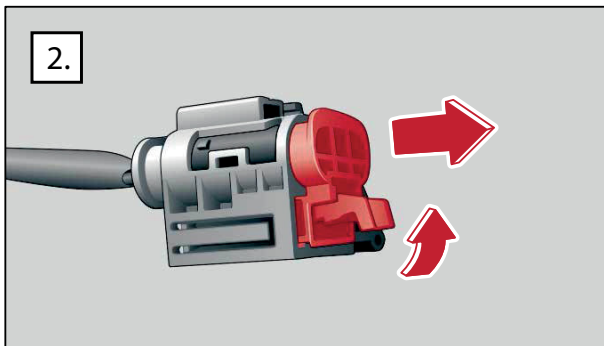

SZ1-0085

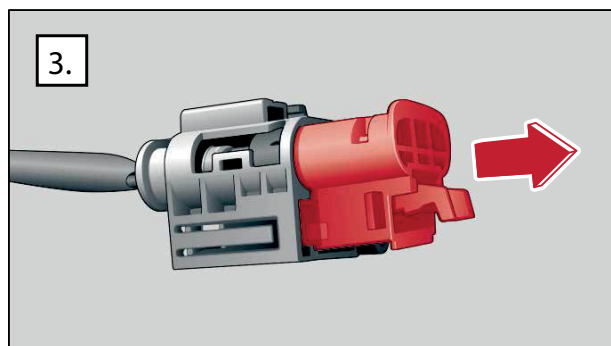

SZ1-0086

### Deactivating the high-voltage system in the vehicle interior

Locate the disconnection point for the high-voltage system in the fuse box inside the passenger compartment.  
Remove the cover from the fuse box and then remove the fuse with the yellow tag (see arrow).  
This disconnects the high-voltage system's control line.

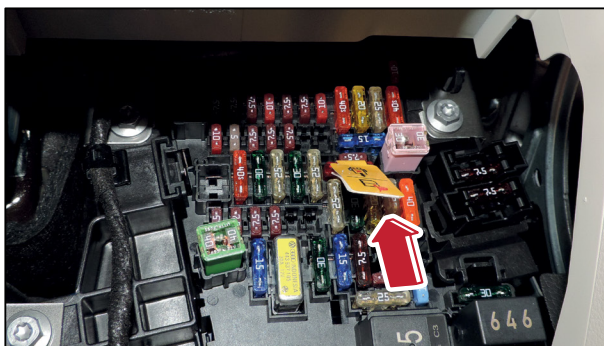

SZ1-0087

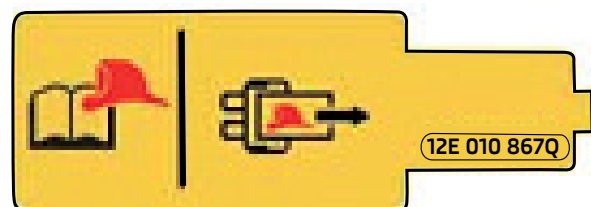

SZ1-0089

## Disconnecting the charging current supply

The charging current supply to the vehicle must be disconnected either at the vehicle or at the charging station/charging socket.

### Disconnecting the charging cable at the vehicle

Use the ignition key or remote control to lock and then unlock the vehicle; this unlocks the charging plug in the vehicle. Remove the charging plug from the vehicle within 30 seconds. The charging port is located in the radiator grille.



SZ1-0090



SZ1-0091

### Disconnecting the charging cable at the charging station/charging socket

Remove the charging plug to stop the charging process.

# Special instructions and safety information for BEV electric vehicles and PHEV hybrid vehicles

## Fire in the vehicle



In the event of a fire, a mixture of water and special wetting agent for extinguishing traction battery fires must be used to extinguish the fire and cool the vehicle in order to prevent a chemical reaction that produces hazardous substances. When tackling fire in vehicles, proceed in accordance with **implementation rule no. 25 of 22.12.2004 (updated on 21.12.2016)**, "Tackling fire with water in the vicinity of electrical equipment and live cables with up to 400 V", issued by the General Directorate of the regional Czech fire rescue service.

If a high-voltage battery catches fire, certified CCS COBRA wetting agent, CO<sup>2</sup> or fire-extinguishing powder can be used to extinguish the fire.

If the high-voltage battery has caught light along with other combustible substances, exercise extreme caution when tackling the fire, as there is a risk of explosion.

When tackling fire, self-contained breathing apparatus and PPE must be worn. The incident commander specifies suitable fire-extinguishing agents (water, foam, powder) and defines fire-extinguishing procedures for different situations. The incident commander also specifies the PPE and breathing apparatus.

The standard safety clearances should be complied with. Do not allow body parts to come into contact with the components of the high-voltage battery.

**Fire-extinguishing agents:** To tackle small fires in the vehicle, use a portable fire extinguisher designed for extinguishing electrical fires, e.g. CO<sup>2</sup>, dry chemical powder, etc.

To tackle a fire in a high-voltage battery, use the certified CCS COBRA high-pressure extinguishing system with the accessory for extinguishing traction batteries. The special fire-extinguishing agent is delivered using the certified CCS COBRA fire-extinguishing spray lance.

Vaporised or decomposed electrolyte can escape from the battery if the battery is heated to over 100 °C (212 °F) or exposed to fire. The dimethyl carbonate in the electrolyte is a flammable liquid and should be kept away from ignition sources.

## Warning



In the event of a fire, a mixture of water and special CCS COBRA wetting agent must be used to extinguish the fire and cool the vehicle in order to prevent a chemical reaction that produces hazardous substances.

Breathing in gases given off when a high-voltage battery catches fire can damage your airways. Touching the components of the high-voltage battery may result in injury to skin and eyes.

Failure to heed the warnings can result in serious injury.

## Information on reactivity



Incompatible substances: Not compatible with oxidising agents, acids, bases or reducing agents.

Hazardous decomposition products:

Lithium hexafluorophosphate may react with water in the air to produce toxic substances, including hydrogen fluoride.

Thermal decomposition can result in toxic phosphorus oxide or phosphine fumes.

## Risk of fire and explosion



Vaporised or decomposed electrolyte may leak from the battery if it heats up above 100°C (212°F) or is exposed to a fire. Dimethyl carbonate contained in the electrolyte is a flammable liquid and should be kept away from fire sources.

Substances contained in the battery:	Creation point	Boiling point
Ethylene carbonate	37°C - 39°C	243°C
Dimethyl carbonate	2°C - 4°C	90°C
Propylene carbonate	-50°C	240°C
Vinylene carbonate	18°C	162°C

Substances dissolved by heat from the battery:	Creation point	Boiling point
Linilit CA <sub>1</sub>	above 1000°C	Not applicable
Lithium hexafluorophosphate	Not applicable	Not applicable
Carbon	3727 °C	4830 °C



Fire-extinguishing agents: CO<sub>2</sub>, dry chemical powder, certified CCS COBRA wetting agent.

## Health risks

Under normal circumstances, the chemicals are safely enclosed in a sealed battery. Therefore, the risk of explosion only occurs when the battery is loaded mechanically or as a result of heat.

### First aid in the event of:

Contact with eyes: Rinse thoroughly with plenty of water immediately and for at least 15 minutes, and seek medical attention immediately.

Contact with skin: Remove contaminated clothing immediately and rinse the affected areas for at least 15 minutes with plenty of water, then wash the skin with soap and water.

Inhalation: Move the injured person into fresh air and seek medical attention immediately.

## Vehicle in water

High-voltage systems are insulated from the vehicle body and are designed to eliminate the risk of electric shock in the surrounding water. High-voltage areas of the vehicle's systems are automatically de-energised in the event of flooding or if there is a risk of short-circuiting.



### **Use insulated fabric straps to recover the vehicle from the water.**

Once the vehicle has been recovered from the water, allow the water to drain from the vehicle. This must be performed with extreme caution because the high-voltage battery supplies the vehicle with a voltage of up to 400 V and there is a risk of electric shock.

**Once the vehicle has been recovered from the water, deactivate the high-voltage system before doing anything else.**

**Once the vehicle has been recovered from the water, a thorough inspection of the vehicle is also required.**

Once the vehicle has been recovered from the water, a thorough inspection of the vehicle is your top priority. This inspection includes checking, for example, whether the insulation has been damaged/has come open and whether there is damage to any of the high-voltage cables and components or the high-voltage battery.

The necessary rescue work, cooling measures and, if required, extinguishing measures can then be carried out on the vehicle.

As per instructions from the incident commander, should there be any escaping operating fluids, use a suitable device to restrict the spread of these on the surface of the body of water.



Once the vehicle has been recovered from the water, proceed in accordance with the decision tree below:

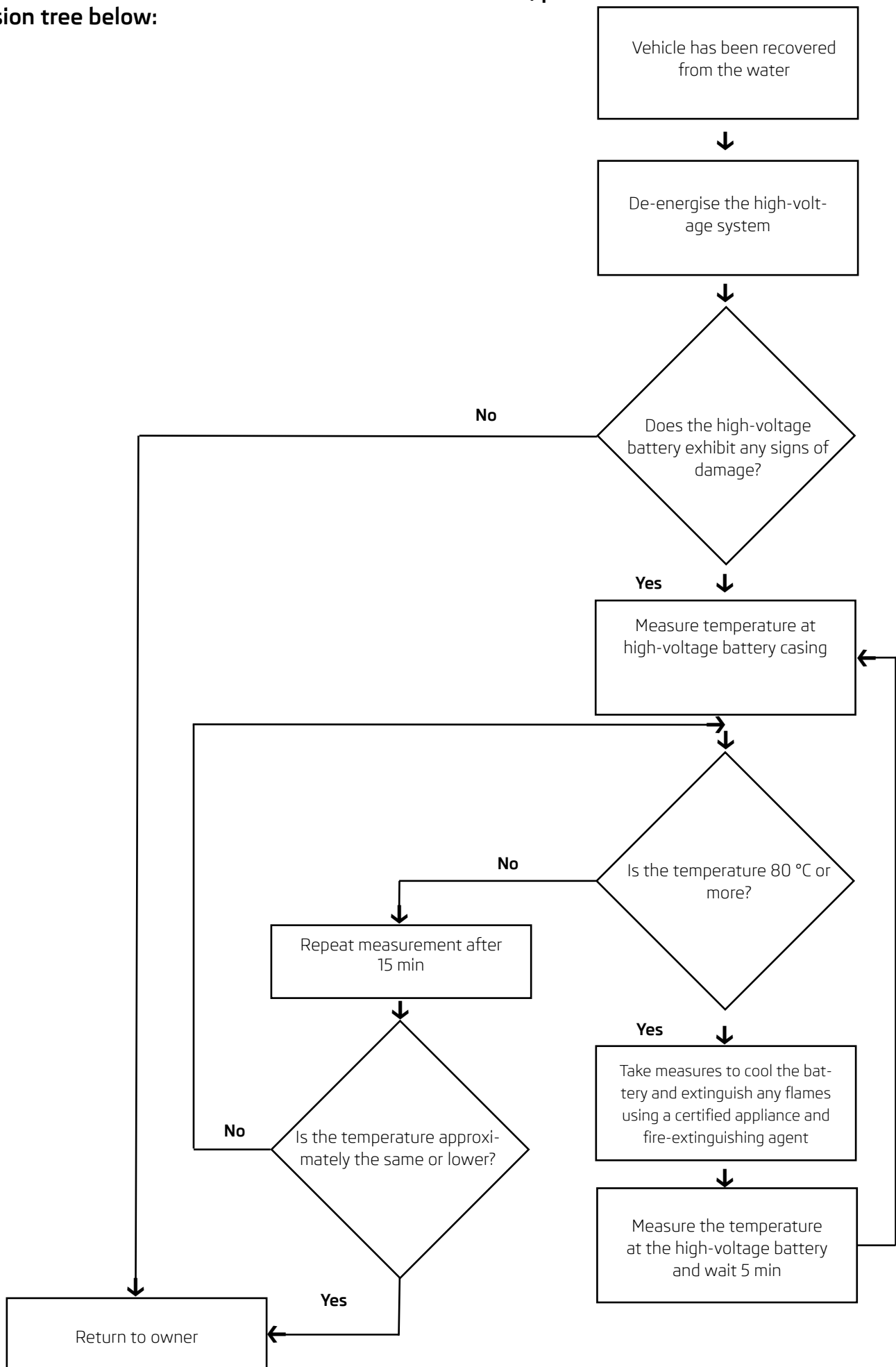

## Towing, transportation, storage



### Caution

Inform the recovery services about any operating fluids that might be escaping.

If an electric vehicle has been involved in a collision, a thorough inspection of the vehicle is your top priority.

This inspection includes checking, for example, whether the insulation has been damaged/has come open and whether there is damage to any of the high-voltage cables and components or the high-voltage battery.

Before loading the vehicle onto the tow truck's load bed, the tow truck driver should check whether the vehicle poses any danger to them and whether it is possible to safely transport the vehicle.

The vehicle cannot be towed using a rope or pulled onto the tow truck's load bed - the vehicle can be loaded using the rotary movement of the vehicle's wheels and the drive shaft will act as a generator. This entails a risk of damaging the unit.

A simple towing operation with both wheels rolling on the road is not possible.

The vehicle that is to be transported must be placed on the tow truck's load bed exclusively by means of a hydraulic arm.

When the vehicle is transported, the high-voltage system must always be deactivated beforehand.

High-voltage batteries may spontaneously ignite.

High-voltage batteries may reignite after the fire has been extinguished.

The tow truck must be equipped with a fire extinguisher and a fire blanket.

Once it has been transported, park the vehicle under quarantine.

It must be parked a safe distance away from buildings and other vehicles.

When the vehicle is stored, the high-voltage system must always be deactivated beforehand.

# SCR system

## Injection system for synthetic urea water solution - SCR

Most currently manufactured ŠKODA vehicles are used to reduce emissions of pollutants, especially nitrogen oxides (NO<sub>x</sub>), the Selective Catalytic Reduction (SCR) system is used.

The SCR system is based on injecting synthetic urea water solution into the discharge line. Selective catalytic reduction takes place. The **AdBlue** trade name is used for this solution.

## Installation in vehicles

The AdBlue reducing agent is carried in a separate auxiliary tank. This is installed behind the wheelhouse at the rear on the right.

The reducing agent filler neck is located next to the fuel filler neck, while the Yeti vehicle. The required quantity of AdBlue is injected into the exhaust stream from the injection valve for the reducing agent in the region between the oxidation catalytic converter (DOC) and the diesel particulate filter (DPF).

## ŠKODA Superb III vehicle

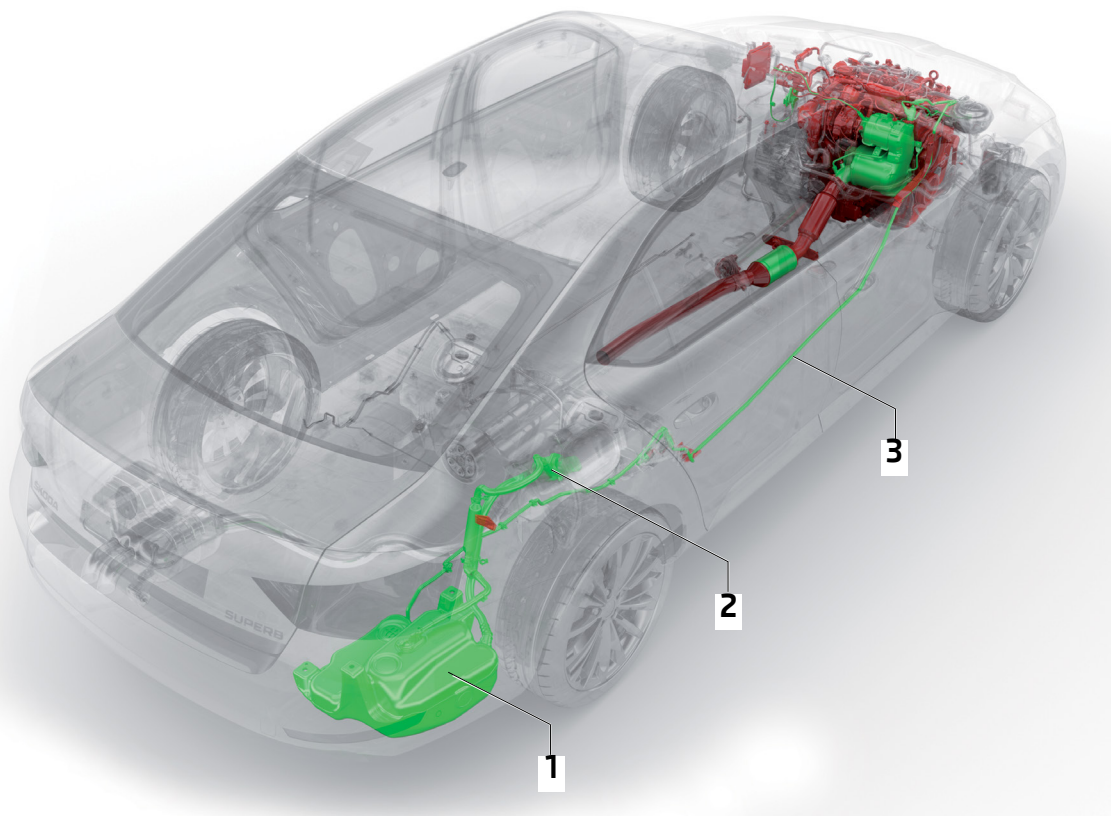

SP 107\_8

1. Heated reducer tank with pump with a capacity of 14 liters
2. Reducing agent filler neck
3. Heated reducing agent line

# AdBlue reducing agent for selective catalytic reduction - SCR

## Chemical formula of the reducing agent

The chemical composition of the AdBlue reducing agent is  $(\text{CO}(\text{NH}_2)_2, \text{H}_2\text{O})$ .

## Composition of the reducing agent

The reducing agent is produced in an accurate percentage composition.

- **32.5%** Synthetic urea;  $\text{CO}(\text{NH}_2)_2$
- **67.5%** demineralised water;  $\text{H}_2\text{O}$

The urea content in the AdBlue is 32.5% to reach the lowest reducing agent solidification point of  $-11^\circ\text{C}$ .

## Properties of the reducing agent

Dropping point:	$-11^\circ\text{C}$
Boiling point:	$103^\circ\text{C}$
State (at $20^\circ\text{C}$ ):	liquid
Color:	colorless
Odor:	decomposes at approx. $70-80^\circ\text{C}$ , possible ammonia odor
PH value (at $0^\circ\text{C}$ ):	slightly alkaline
Flammability:	not flammable
Explosive properties:	not explosive

## Specification according to DIN 70070

	Min	Max
Density (at $20^\circ\text{C}$ )	1.0870	$1.0930 \text{ g / cm}^3$
Refractive index (at $20^\circ\text{C}$ ):	1.3814	1.3843
Alkalinity as $\text{NH}_3$	0.2%	
Biuret	0.3 %	
Aldehyde	5.0 mg / kg	
Undissolved substances	20 mg / kg	
Phosphate ( $\text{PO}_4$ )	0.5 mg / kg	
Calcium	0.5 mg / kg	
Iron	0.5 mg / kg	
Copper	0.2 mg / kg	
Zinc	0.2 mg / kg	
Chromium	0.2 mg / kg	
Nickel	0.2 mg / kg	
Aluminum	0.5 mg / kg	
Magnesium	0.5 mg / kg	
Sodium	0.5 mg / kg	
Potassium	0.5 mg / kg	

## Hazardous decomposition products

The following dangerous products may appear in the event of a fire or in contact with hot vehicle parts:

- Nitrogen oxides ( $\text{NO}_x$ )
- Ammonia ( $\text{NH}_3$ )
- Carbon dioxide ( $\text{CO}_2$ ) and carbon monoxide ( $\text{CO}$ )

# Emergency call

## ERA-GLONASS emergency call system

The ERA GLONASS emergency call system is only operational for some countries (Russia, Belarus, Kazakhstan, Moldova, etc.). The emergency call system is used for automatic or manual connection between the vehicle and the emergency call center.

Availability of a mobile network is indispensable for system function. An emergency call cannot be made if a mobile network is not available.

The rescue system emergency call works automatically (in the event of heavier collisions). If necessary, help can be called up manually by pressing the red key in the emergency call system.

### Automatic connection setup

The OCU control unit for online services automatically connects to the emergency call center in the event of an accident with an airbag release.

During all emergency connections, the OCU control unit sends the following vehicle and occupant data at the time of the accident:

ID:	MSD format version
Message identifier:	Identifier of each new eCall set
Control:	Trigger type (automatic / manual, normal / eCall test, position trustworthiness, vehicle type)
VIN:	Vehicle identification number according to Iso 3739
Propulsion storage type:	Fuel type
Time stamp:	Time of the eCall event in seconds from 1.1.1970 UTC
Vehicle location:	Vehicle position (latitude and longitude)
Vehicle direction:	Direction of travel before the impact in 2° step from the magnetic north pole
Recent vehicle location:	Previous vehicle positions, expressed by the difference in latitude and longitude
Number of passengers:	Number of safety belts

The scope of intervention for the rescue workers is evaluated based on this information. The crew will be contacted to provide more information about the rescue work.

Communication between the vehicle crew and the emergency call center takes place via an independent loudspeaker installed in the vehicle and the microphone.

In the event of a minor accident, the system automatically provides the emergency call number via the infotainment screen.

### Triggering conditions

The ignition is switched on.

The GPS signal is available.

A GSM network is available.

The emergency call system is not faulty and the airbag control unit is in the off position.

### Manual connection setup

In the event of a minor accident or vehicle crew health problems, the emergency call center can be contacted directly. The connection is established by pressing the button (Pos. 1) (after opening the cover cap) for more than 3 s. The connection can be terminated by pressing the button again.

After the connection has been established, communication with the emergency call center takes place via the independent loudspeaker installed in the vehicle and the microphone.

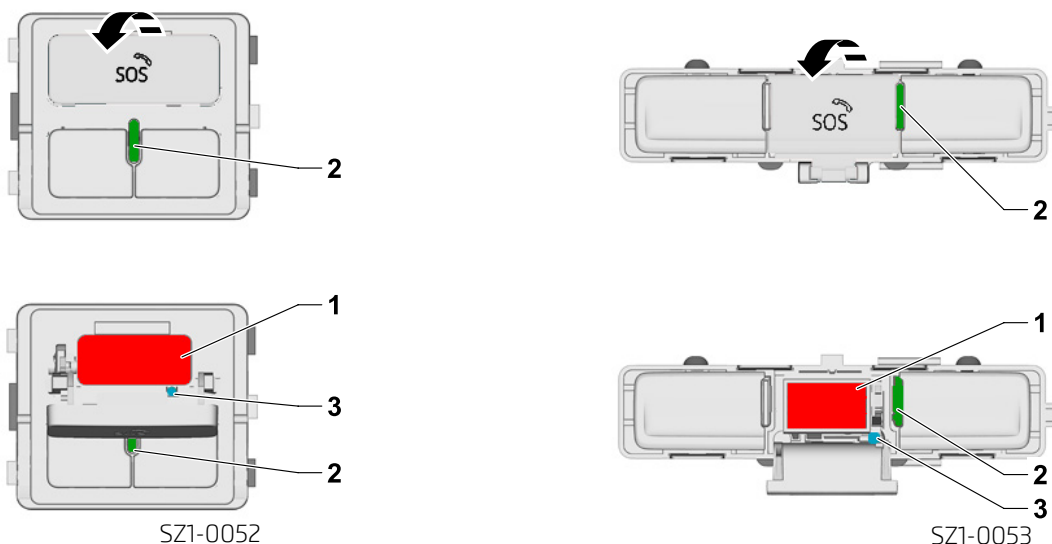

## ERA-GLONASS emergency call system control element

### Emergency call system operating element, version 1

To reach the SOS safety button (pos. 1), first open the cover cap in the direction of the arrow.

The status LED (item 2) always lights up red for approx. 4 s and lights up when a system error occurs (can affect the function according to the type of fault detected using diagnostics).

The emergency call system is active (ready for operation) if the status LED is then green after approx. 4 s.

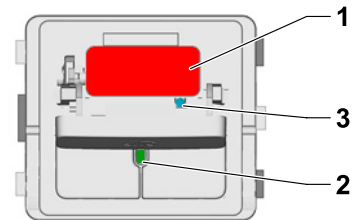
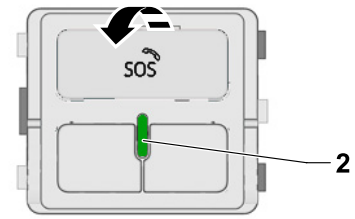

SZ1-0052



The key (Pos. 1s) is intended for the emergency call system test. This key is used to check all emergency call system components (e.g. OCU control unit, SW integrity and real time, loudspeaker, microphone, SOS key, etc.) before the vehicle is handed over to the customer.

### Emergency call system operating element, version 2

To reach the SOS safety button (pos. 1), first open the cover cap in the direction of the arrow.

The status LED (item 2) always lights up red for approx. 4 s and lights up when a system error occurs (can affect the function according to the type of fault detected using diagnostics).

The emergency call system is active (ready for operation) if the status LED is then green after approx. 4 s.

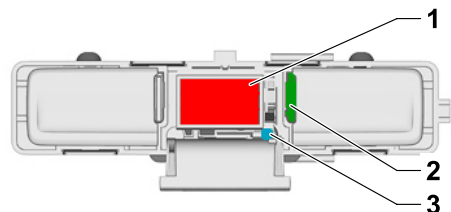
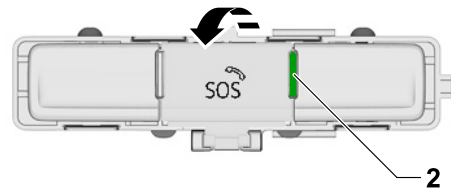

SZ1-0053



The key (Pos. 1s) is intended for the emergency call system test. This key is used to check all emergency call system components (e.g. OCU control unit, SW integrity and real time, loudspeaker, microphone, SOS key, etc.) before the vehicle is handed over to the customer.



## eCall emergency call system

The eCall emergency call system is operational for the Czech Republic, the EU and some other countries (e.g. Switzerland, Norway, etc.).

The emergency call system is used for automatic or manual connection to the emergency call number 112.

Availability of a mobile network is indispensable for system function. An emergency call cannot be made if a mobile network is not available.

The rescue system emergency call works automatically (in the event of heavier collisions). If necessary, help can be called up manually by pressing the red SOS key in the emergency call system.

During the emergency call, the OCU control unit sends vehicle and occupant data to emergency call center 112 at the time of the accident or to the provider of this service, BOSCH service.

The service provider BOSCH service then transmits the evaluated data to emergency call center 112.

Information transmission (data transmission) using the service provider BOSCH service is dependent on the technical capability of emergency call center 112 to currently accept and process this information (data) in some countries.

The scope of intervention for the rescue workers is evaluated based on this information. The crew will be contacted to provide more information about the rescue work.

### Triggering conditions

The ignition is switched on.

The GPS signal is available.

A GSM network is available.

The emergency call system is not faulty and the airbag control unit is in the off position.

### Automatic connection setup

The control unit for on-line services OCU automatically establishes a connection to the emergency call center or to the provider of this service BOSCH service in the event of an accident by triggering the airbag.

The provider of this service, BOSCH service, then transmits the evaluated data to emergency call center 112.

During all emergency connections, the OCU control unit sends the following vehicle and occupant data at the time of the accident:

ID:	MSD format version
Message Identifier:	Identifier of each new eCall set
Control:	Trigger type (automatic / manual, normal / eCall test, position trustworthiness, vehicle type)
VIN:	Vehicle identification number according to Iso 3739
Propulsion storage type:	Fuel type
Time stamp:	Time of the eCall event in seconds from 1.1. 1970 UTC
Vehicle location:	Vehicle position (latitude and longitude)
Vehicle direction:	Direction of travel before the impact in 2° step from the magnetic north pole
Recent vehicle location:	Previous vehicle positions, expressed by the difference in latitude and longitude
Number of passengers:	Number of safety belts

The scope of intervention for the rescue workers is evaluated based on this information. The crew will be contacted to provide more information about the rescue work.

Communication between the vehicle crew and the emergency call center takes place via an independent loudspeaker installed in the vehicle and the microphone.

In the event of a minor accident, the system automatically provides the emergency call number or breakdown number via the infotainment screen.

### Manual connection setup

In the event of a minor accident or vehicle crew health problems, the emergency call center can be contacted directly.

The connection is established by pressing the SOS key for more than 3 s.

The connection can be terminated by pressing the button again.

After the connection has been established, communication with the emergency call center takes place via the independent loudspeaker installed in the vehicle and the microphone.

## The ECall emergency call system operating element

### Emergency call system operating element, version 1

#### System function

When the ignition is switched on, the emergency call system is shown by the indicator light (arrow) illuminating. If the system is working properly, the indicator light is green. In the event of a system fault, the indicator light will turn red.

#### Information button (i)

Pressing the button activates connection to the ŠKODA Infoline.

#### Service button (key)

Pressing the button activates connection to the associated emergency assistance center in the country of vehicle registration for troubleshooting purposes.

#### SOS button

Pressing the button activates the connection to the emergency call center 112 or the provider of this service, BOSCH service.

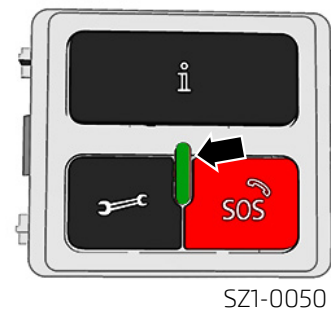

### Emergency call system operating element, version 2



## Location of the emergency call system control element

### Installation location of the emergency call system control element, version 1, e.g. in Octavia III, Yeti vehicles

The emergency call system control element is located in the interior light area in the front roof panel (arrow).



SZ1-0047

### Installation location of the emergency call system control element, version 2, e.g. in Kodiaq, Superb III, Fabia III, Rapid vehicles

The emergency call system control element is located in the interior light area in the front roof panel (arrow).

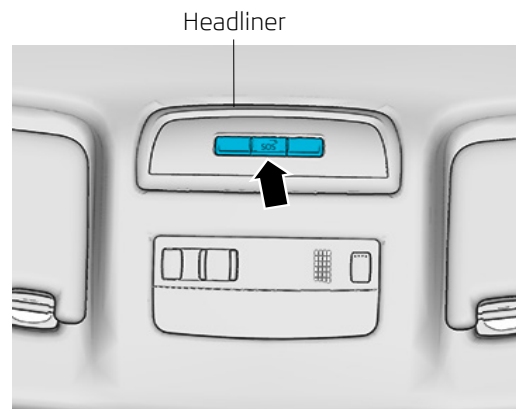

SZ1-0048

# Air conditioning refrigerant

## Refrigerant R12

The refrigerant with the sum formula  $\text{CCl}_2\text{F}_2$  Dichlorodifluoromethane was produced under the designation R12. At the beginning of the nineties, it was proven that this refrigerant destroys the ozone layer. Its use in air-conditioning systems was forbidden in 1995.

## Refrigerant R134a

Under the designation R134a, the refrigerant is protection with the sum formula  $\text{CH}_2\text{FCF}_3$  tetrafluoroethane. It has no chlorine atoms, as was the case with refrigerant R12, the use of which was unacceptable due to its high ozone depletion potential. The refrigerant R134a is CFC-free and has no ozone depletion potential. However, as a greenhouse gas, it is harmful to the environment. It is atoxic and incombustible.

## Refrigerant R1234yf

The new HFO refrigerant R1234yf with the sum formula  $\text{CF}_3\text{CF}=\text{CH}_2$  tetrafluoropropene, has been developed to reduce greenhouse gas emissions as a substitute for refrigerant R134a. This complies with global environment standards. It has no ozone depletion potential and is atoxic.

## Effects of refrigerants CFC, HFC and HFO on the environment in comparison

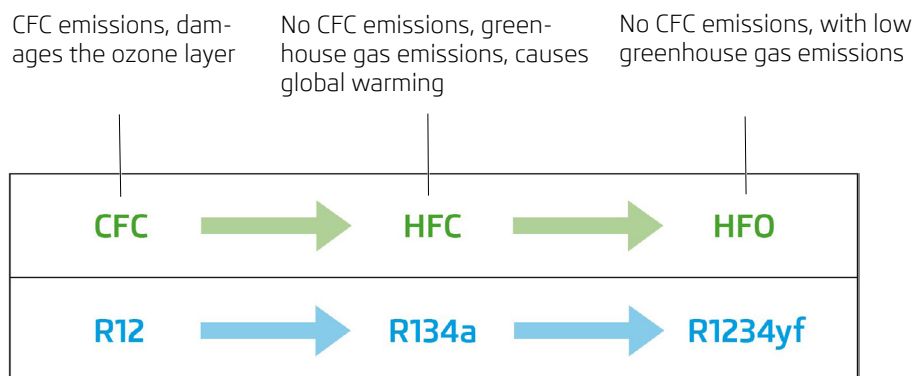

## Flammability of refrigerant R1234yf

Refrigerant R1234yf is combustible within certain ambient air concentrations. The refrigerant decomposes when exposed to fire or when exposed to hot surfaces. This produces toxic substances (carbon monoxide, hydrogen fluoride, hydrogen halide). Decomposition also occurs by exposure to UV radiation, which is part of daylight.

The refrigerant R1234yf must be stored separately according to regulations for storing highly dangerous substances.

## Reaction of refrigerant R1234yf with metals and plastics

In its pure state, refrigerant R1234yf is chemically stable and does not attack, for example, iron, aluminum and plastics that have been appropriately developed and are therefore suitable. Unsuitable materials not developed for this refrigerant can be attacked or damaged.

## Color and smell of refrigerant R1234yf

As a vapor and liquid, refrigerant R1234yf is colorless like water. Gas is invisible. Only the boundary layer between liquid and gas is visible. Refrigerant R1234yf is almost odorless, if it leaks, a slight smell can be determined after ether.

## Information signs for the refrigerant circuit

The label provides information on the type of refrigerant used, the amount of refrigerant added during production, and the type of refrigeration oil used. Symbols on the label indicate the dangers that may arise when handling the refrigerant and when working on the refrigerant circuit.

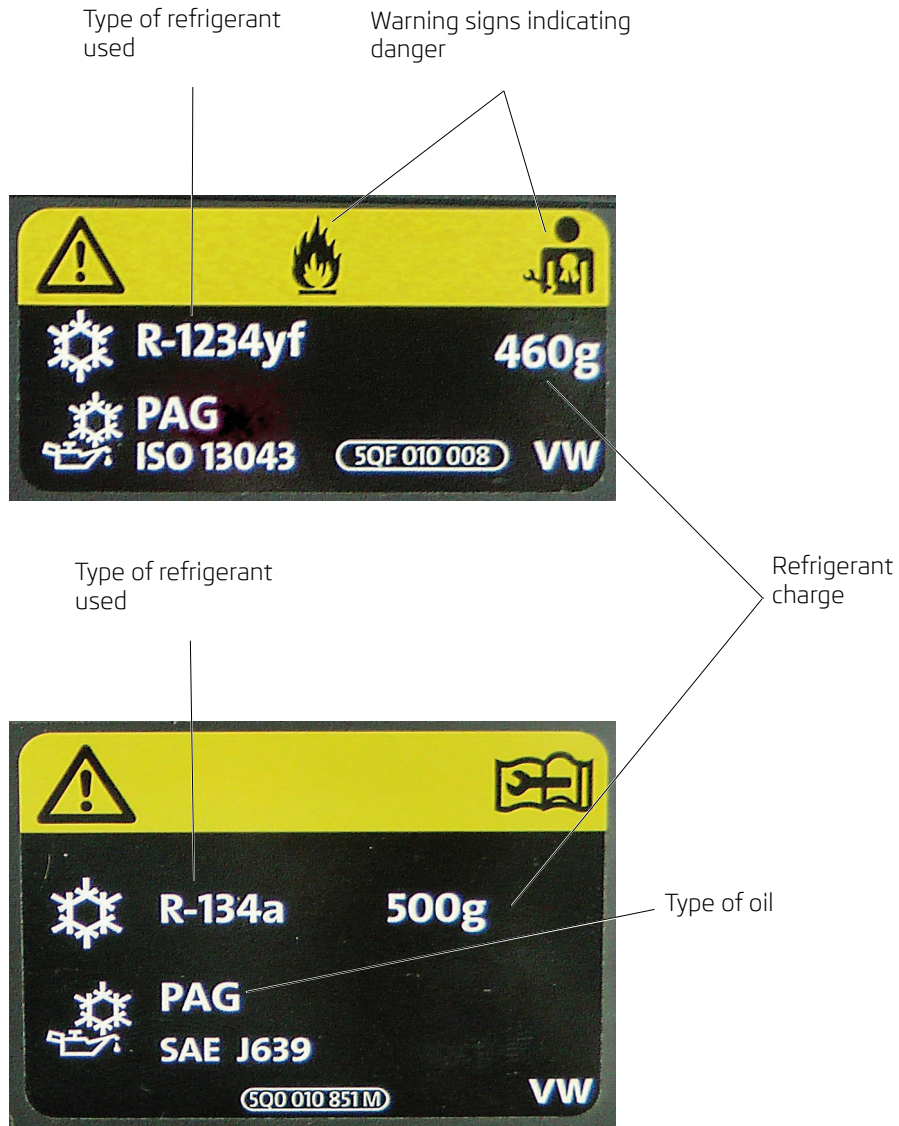

The sign for the refrigerant circuit is located in the engine compartment on the lock carrier or in the water box. The sign is visible after opening the front flap.

The sign can also contain standards and standards. For example, SAE standards and ISO standards.

SAE J639 - describes safety instructions for car air conditioning systems.

SAE J842 - describes the use of components and materials approved for refrigerant R1234yf.

SAE J2845 - indicates that service work on the air-conditioning system's refrigerant circuit may only be carried out by certified and certified persons.

## Notes





Information on technical specifications, construction, equipment and materials relating to the issue date of these guidelines. The manufacturer reserves the right to make changes.